

INSTRUCTION AND OPERATING MANUAL  
FOR

MODEL 335E
TV MONITOR
Serial <del>15</del>

2.620

HEWLETT-PACKARD COMPANY  
395 PAGE MILL ROAD, PALO ALTO, CALIFORNIA, U. S. A.  
1501

## General Description

The Model 335E Television Monitor is designed to give a continuous indication of the frequency deviation of the aural and video transmitters and the modulation percentage of the aural transmitter of a TV station. The frequency range of this instrument covers all TV channels, 2 to 83.

The Model 335E also includes a peak modulation indicator which may be set to give a warning when the modulation exceeds any pre-determined value between 50% and 120%. Provision has been made for the operation of remote indicating meters as well as a remote peak modulation indicator. An audio output voltage is also available for measurement purposes.

## CAUTION

READ THE INSTALLATION AND OPERATING INSTRUCTIONS CAREFULLY BEFORE ATTEMPTING TO USE THIS INSTRUMENT.

## Parts Substitutions

Difficulties in procuring some of the parts used in this instrument may cause the electrical or physical values to deviate from those shown in this instruction manual. These substitutions have been made so as not to impair the performance of this instrument. Whenever replacement of any of these parts is necessary, either the substitute value or the original value may be used.

26.201250  
52.402500 MC

335E, 1/22/54 Serial 1 and above

# INSTRUCTIONS

MODEL 335E

TV MONITOR

## Specifications

### Carrier Frequency Range --

Channels 2 - 83 inclusive, including offset channels.

This instrument, Serial 15, is adjusted for the following carrier frequency.

<u>Channel</u>	<u>Offset</u>	<u>Aural Carrier Frequency</u>	<u>Master Oscillator Crystal Frequency</u>
<u>12</u>	<u>10kc</u>	<u>209.76</u> Mc.	<u>26.201250</u> Mc.

### Visual Carrier Frequency

205.26 Mc.

### Visual Frequency Monitor --

Deviation Range -  $\pm 1.5$  Kc from assigned frequency.

Accuracy - Better than  $\pm 500$  cycles/second for at least a 10 day period.

### Aural Frequency Monitor --

Deviation Range -  $\pm 6$  Kc from assigned frequency.

Accuracy - Better than  $\pm 1,000$  cycles/second for at least a 10 day period.

### Aural Modulation Meter --

Range - 0-133%, Meter indicates 100% on a 25 Kc swing and 133% for a 33.3 Kc swing.

Accuracy - Within  $\pm 5\%$  over entire scale.

Indicating Meter Characteristics - Meter damped in accordance with F.C.C. requirements.

Frequency Response - Flat within  $\pm 1/2$  db from 50 to 15,000 cycles/second.

### Peak Modulation Indicator --

Adjustable to indicate modulation in excess of any predetermined percentage between 50% and 120%.

### Audio Output --

Frequency Range - 50 to 15,000 cps. Response flat within  $\pm 1/2$  db. Equipped with standard 75 microsecond de-emphasis circuit.

Distortion - Less than .25% at 100% modulation.

Output Voltage - 10 volts into 100,000 ohms at 100% modulation at low frequencies.

Monitoring Output - 1 milliwatt into 600 ohms, balanced, at 100% modulation, at low frequencies.

Residual Noise - At least 60 db below output level corresponding to 100% modulation at low frequencies.

R. F. Power Required --

Visual and aural carriers each require less than 1 watt.

External Meter Terminals --

Terminals are provided for connecting external meters (aural and visual deviation, aural modulation) and a peak modulation indicator lamp to the instrument.

Power Supply Rating --

Voltage - 115 volts

Frequency - 50/60 cycles/second

Wattage - 180 watts

Accessories Furnished --

Cables -

	<u>Type of Cable</u>	<u>Length</u>	<u>Terminations</u>
Power	3 cond. rubber covered	7-1/2 ft.	Motor base plug one end - 2 prong plug other end.

Connectors -

<u>Type</u>	<u>Quantity Furnished</u>
UG21B/U	2

Overall Dimensions --

12-1/4" high x 19" wide x 15" deep.

Weight --

60 pounds.

## Operating Instructions

### Inspection --

This instrument has been thoroughly tested and inspected before being shipped and is ready for use when received.

After the instrument is unpacked, it should be carefully inspected for damage received in transit. If any shipping damage is found, follow the procedure outlined in the "Claim for Damage in Shipment" section on the last page of this instruction book.

### Controls and Terminals --

CRYSTAL TEMPERATURE - This thermometer indicates the temperature of the master oscillator crystal oven.

PEAK MODULATION INDICATOR - This red indicator lamp lights whenever the aural modulation percentage exceeds any pre-determined value between 50% and 120%.

50% - 120% - This control is provided to set the modulation percentage above which the PEAK MODULATION INDICATOR lamp will be lighted.

A - The VISUAL CARRIER DEVIATION meter pointer is set to zero with this control. (See Maintenance Section).

B - This control is used to adjust the VISUAL CARRIER DEVIATION meter calibration. (See Maintenance Section).

CRYSTAL TUNING - This variable capacitor is provided to adjust the master oscillator crystal frequency.

J1 - The phone jack labeled J1 is provided so that an audio voltage may be applied to the visual amplifier and counter circuit for the purpose of calibrating the VISUAL CARRIER DEVIATION meter.

TEST - This pushbutton is provided so that a simple test may be made to determine whether or not the visual carrier has deviated 7 Kc and therefore is producing a false zero indication on the VISUAL CARRIER DEVIATION meter.

CARRIER LEVEL ---CALIBRATE - The function of this switch is to connect the circuits and meters in the various combinations required to monitor the aural and visual transmitters, check on the performance of the instrument, and to determine if an adequate carrier level is available to operate the instrument. Listed below are the switch positions and the functions performed at each position.

CARRIER LEVEL - In this position the VISUAL CARRIER DEVIATION meter and AURAL CARRIER DEVIATION meter are connected to measure the level of their respective carriers. The AURAL CARRIER MODULATION meter does not function with the switch in this position.

1 - The AURAL CARRIER MODULATION meter measures the grid current of the first multiplier when the switch is set to position 1. The other two meters measure the grid current of their respective mixers.

USE - In this position the instrument is connected to monitor the television transmitter.

2 - This position of the switch connects the VISUAL CARRIER DEVIATION meter so as to measure the grid current of the 4.3535 Mc crystal oscillator. The AURAL CARRIER DEVIATION meter and the AURAL CARRIER MODULATION meter indications have no significance.

CALIBRATE - In this position the VISUAL CARRIER DEVIATION meter is used to measure the grid current of the 150 Kc oscillator. The AURAL CARRIER MODULATION meter and the AURAL CARRIER DEVIATION meter are connected so that their calibrations may be adjusted by the controls C and D respectively.

POWER - This switch controls all power supplied to the instrument with the exception of the crystal oven heater circuits. The crystal oven circuits are energized at all times for maximum stability.

FUSE - The fuseholder, located on the control panel, contains a 3.2 ampere cartridge fuse. To replace the fuse, unscrew the fuseholder cap, remove the blown fuse, and replace with a new fuse of the "Slo-blo" type as specified in the Replaceable Parts Table.

C - This control is used to adjust the AURAL CARRIER DEVIATION meter pointer to zero. (See Maintenance Section).

D - This control is used to set the AURAL MODULATION meter to 100%. (See Maintenance Section).

MODULATION POLARITY - The position of this switch indicates the polarity of the modulation indicated by the AURAL CARRIER MODULATION meter.

#### EXTERNAL METERS

AURAL-MOD-VISUAL - These three coaxial jacks (J4, J6, J7) are provided for connecting external meters to the instrument. Whenever external meters are not connected to the terminals, the dummy meter loads furnished with the instrument must be connected. The dummy meter loads are 3000 ohms each for the AURAL and VISUAL terminals and 1000 ohms for the MOD. terminal.

1 - 8 -- The terminals on this terminal board are identified as follows:

Low Z (1 and 2) -- Low impedance audio output terminals for monitoring purposes. Terminals 3 and 4 must be tied together to obtain the audio voltage at terminals 1 and 2. One milliwatt into 600 ohms, balanced, at 100% modulation at low frequencies is available across terminals 1 and 2. This output is equipped with a standard 75 microsecond de-emphasis circuit.

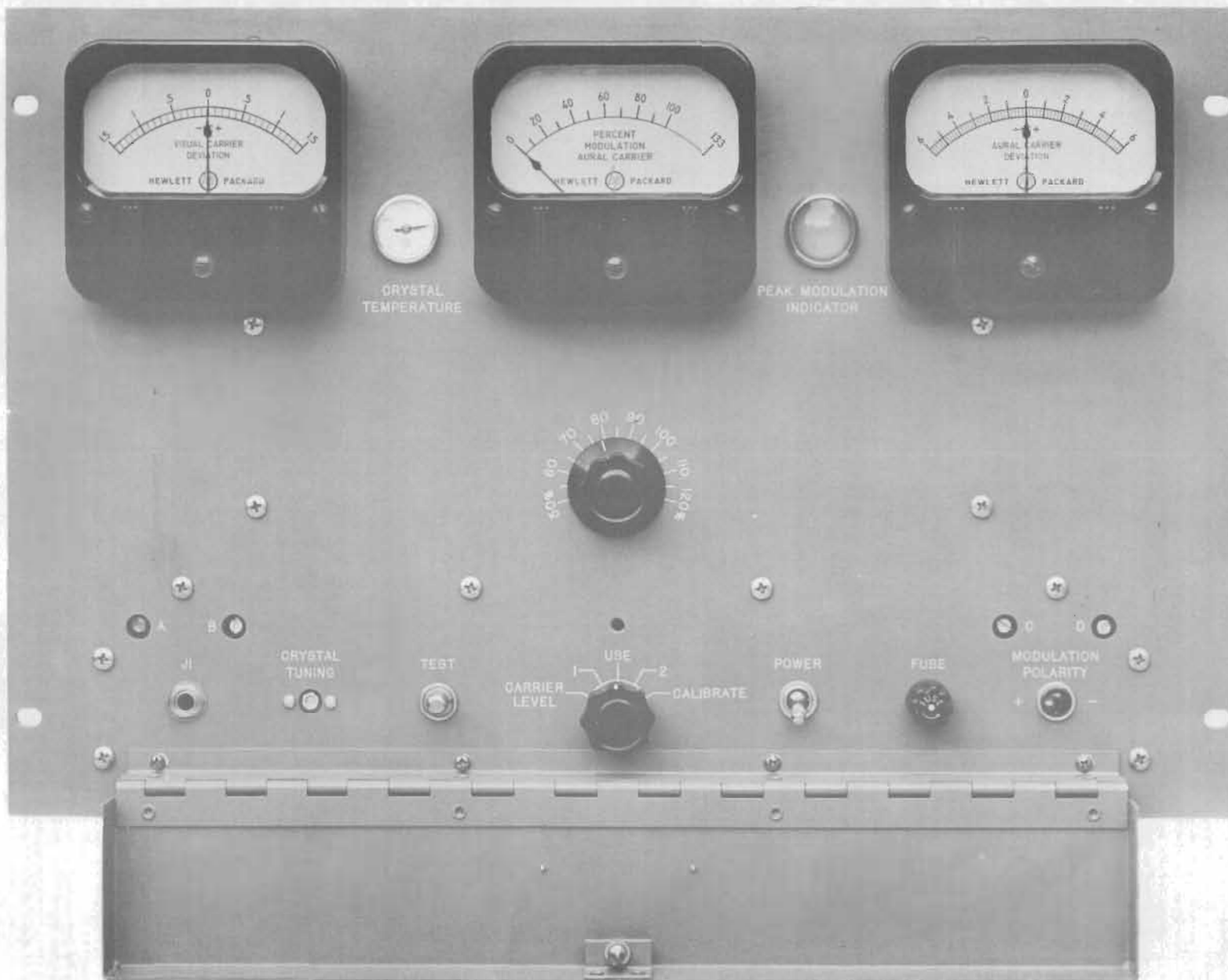

Fig. 1. Model 335E TV Monitor (Panel Door Open)

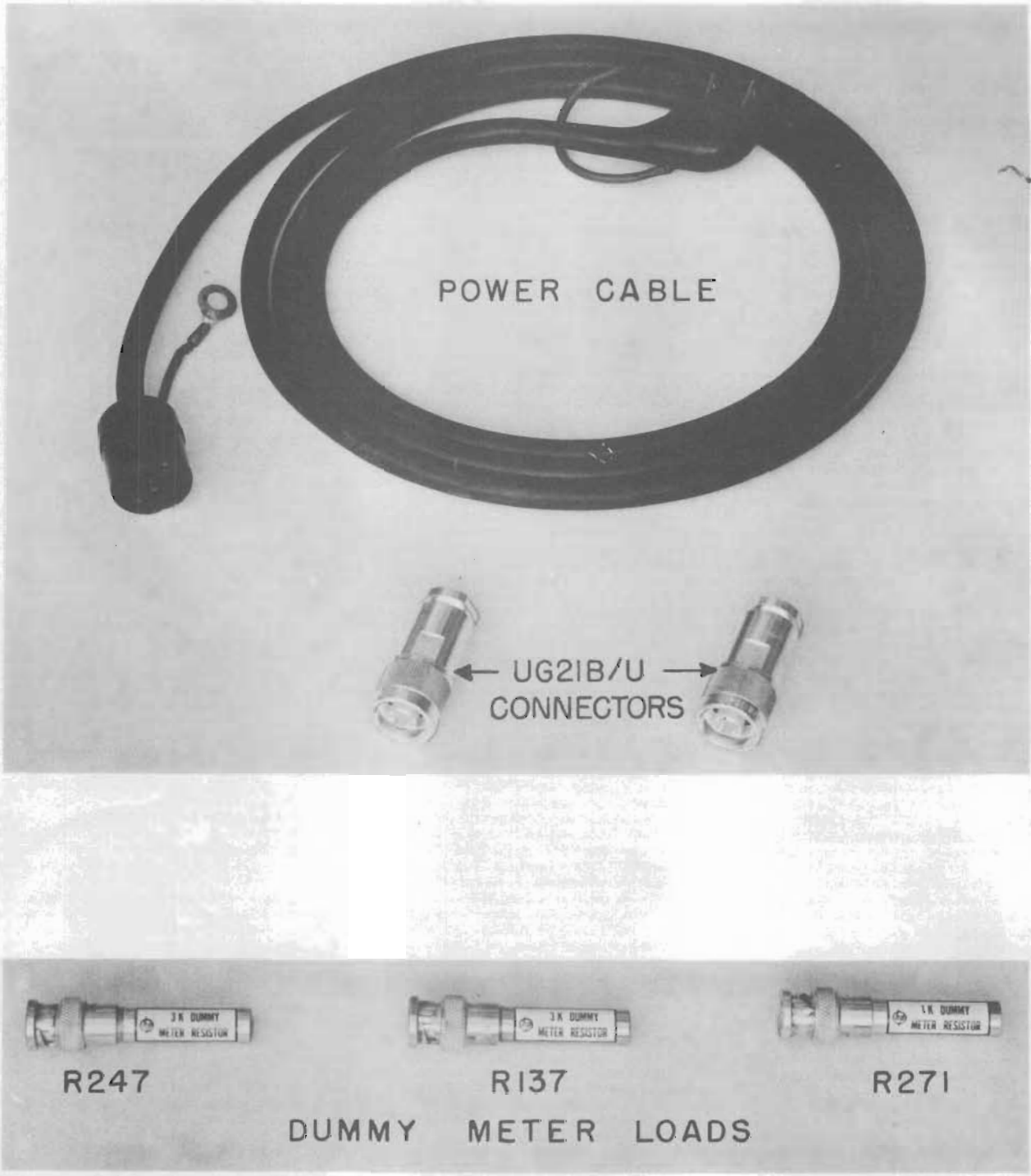

Fig. 2. Accessories Furnished with Model 335E



HI-Z (4 and 5) -- Ten volts into 100,000 ohms at 100% modulation at low frequencies. This output is equipped with a standard 75 microsecond de-emphasis circuit.

6 -- This terminal is provided for connecting test equipment to the instrument for calibrating the AURAL CARRIER MODULATION meter. The IF frequency may also be measured at this terminal.

Lamp (7 and 8)-- An external peak modulation indicator lamp can be connected to these terminals. A 120 volt, 3 or 6 watt lamp should be used.

FUSE - 1/2 AMP. - The fuseholder, located on the back of the instrument, contains 1/2 ampere cartridge fuse. To replace the fuse, unscrew the fuseholder cap, remove the blown fuse, and replace with a new fuse of the same type.

This fuse protects the crystal oven heater circuit.

J5 - This jack provides a connection for measuring the spurious amplitude modulation on the aural carrier.

#### RF INPUTS -

AURAL - This coaxial connector is the input terminal for the coaxial cable from the aural transmitter.

VISUAL - This coaxial connector is the input terminal for the coaxial cable from the video transmitter.

Power Cable - This is a special three conductor cable with a standard two prong male plug molded on one end and a two contact motor base plug on the other end. The third conductor (green) protrudes from the power cable near each plug and may be used to connect the instrument chassis to an external ground.

#### Installation --

The Model 335E Television Monitor is designed to be mounted in a standard relay rack. For dependable operation the monitor should be installed in a well ventilated rack where the air temperature does not exceed 113°F (45°C.). It is also important to leave clearance behind the unit to allow adequate passage of air through the air filter in the back of the dust cover.

External meters and an external peak modulation indicator lamp assembly may be purchased from the Hewlett-Packard Company. Write the factory if you desire any of these accessories.

All connections to the monitor should be made with shielded cable with the exception of the power cord and the wiring for the external peak modulation indicator. Both RF inputs and the external meter connections should be made with coaxial cable, the audio output connections should be made with double conductor shielded wire.

## Coaxial Cables and Connectors --

<u>Function</u>	<u>Cable</u>	<u>Connector</u>
RF INPUTS	RG-9/U, RG-8/U, RG-9A/U, RG-10/U RG-55/U, RG-58/U	UG-21B/U, UG-21D/U UG-536/U
EXTERNAL METERS	RG-55/U	UG-88/U

### CAUTION

Do not attempt to adjust the CRYSTAL TUNING control until the instrument has been completely installed and connected to the power line for a continuous period of 24 hours.

When coupling the monitor to the transmitter never couple excessive power into the monitor. A fraction of one watt is all the RF power required by the monitor from each transmitter. Excessive input may permanently damage the RF section of the instrument.

When installing the monitor follow the step by step procedure outlined below. The instrument has been thoroughly tested before shipment and should require only minor adjustments during installation.

### Initial Installation Procedure --

1. Connect the instrument to the power line (115 volt  $\pm$  10%, 50/60 $\wedge$ ) and allow it to warm up for at least one hour. Watch the CRYSTAL TEMPERATURE thermometer during this warm-up; it should not exceed 68 $^{\circ}$ C (outside green sector). If the CRYSTAL TEMPERATURE rises above 68 $^{\circ}$ C, it indicates that the unit should be disconnected from the power line and the mercury thermostat in the crystal oven removed and examined. In most cases the thermostat can be restored to correct operation by repeated heating and cooling. This will unite the mercury column and the unit will operate properly. See the Maintenance section of this manual for the complete crystal oven service procedure.

2. Connect the dummy meter loads (three are provided with each instrument) to the EXTERNAL METER jacks on the rear of the instrument. The 1000 ohm load should be connected to the MOD. jack and the 3000 ohm loads connected to the AURAL and VISUAL jacks.

3. Set the Function Selector (behind the door on the panel) to the CALIBRATE position. Adjust control "C" until the AURAL CARRIER DEVIATION meter indicates exactly zero. Adjust control "D" until the PERCENT MODULATION meter indicates exactly 100%. These controls adjust the aural counter circuits for correct operation.

4. This step requires an external audio oscillator such as the Hewlett-Packard Model 200AB or Model 200CD. Set the Function Selector to the USE position. Adjust the oscillator for approximately one volt output at 3500 cycles/sec. and connect it to J1 on the panel. Adjust control "A" until the VISUAL CARRIER DEVIATION meter indicates exactly zero. Set the audio oscillator for one volt output at 5000/sec. and adjust control "B" until the VISUAL CARRIER DEVIATION meter indicates exactly +1.5 Kc. Change the oscillator output to 2000 cycles/sec., the VISUAL DEVIATION meter should indicate -1.5 Kc. If it does not, re-adjust control "B" until equal accuracy is obtained at both ends of the deviation meter range. The VISUAL CARRIER DEVIATION meter circuits are now calibrated.

5. Set the Function Selector switch to the "1" position. The VISUAL CARRIER DEVIATION meter should indicate at least +.5 Kc (RF inputs not connected), and the AURAL CARRIER DEVIATION meter should indicate at least +2 Kc. If they do not, refer to the Maintenance section of this manual.

6. Set the Function Selector switch to the "2" position. The VISUAL CARRIER DEVIATION meter should indicate at least +.5 Kc., if it does not, refer to the Maintenance section of this manual.

7. Set the Function Selector switch to the CARRIER LEVEL position. Connect the VISUAL RF INPUT to the sampling probe in the visual transmitter and adjust the probe until the VISUAL CARRIER DEVIATION meter indicates between +.5 and +1.5 Kc. (No visual modulation should be applied to the visual transmitter, other than synchronizing pulses; i. e., the visual transmitter should be transmitting a "black" level.) Connect the AURAL RF INPUT to the sampling probe in the aural transmitter and adjust this probe until the AURAL CARRIER DEVIATION meter indicates between +2 and +6 Kc.

8. Switch to the USE position. Press the TEST switch; the VISUAL CARRIER DEVIATION meter indication should increase (deflect to the right) between 100  $\mu$  and 1 Kc. This indicates that the monitor is properly tuned for the channel involved. If this indication is not obtained, refer to the Maintenance section of this manual.

9. The remaining connections should be made at the rear of the instrument as follows:

External Meters - Remove the dummy meter loads and connect the external meters to their appropriate jacks.

External Peak Modulation Indicator - An external indicator may be connected to terminals 7 and 8 on the back of the instrument. A 120 volt, 3 or 6 watt lamp should be used for this purpose.

Audio Output - 600 ohms balanced output, connect to terminals 1 and 2 and jumper terminals 3 and 4. High impedance unbalanced output, connect to terminals 4 and 5 (gnd.) and remove any connection between terminals 3 and 4.

10. With the exception of the final crystal oscillator adjustment, the instrument is now ready for use. Do not attempt to adjust the CRYSTAL TUNING

control until the instrument has been connected to the power line for a continuous period of 24 hours and the POWER switch has been on at least one hour. Follow the Crystal Oscillator Adjustment Procedure when making any adjustment of the CRYSTAL TUNING control.

During normal operation of the instrument the Function Selector switch is left in the USE position.

#### Crystal Oscillator Adjustment Procedure --

The CRYSTAL TUNING control should not be adjusted without consulting an approved monitoring service. No adjustments should be attempted until the unit has been connected to the power line (crystal oven operating) for a continuous period of 24 hours and the complete instrument turned on for at least one hour.

The best method of adjusting the CRYSTAL TUNING control requires telephone contact with the standard monitoring service. Adjust the CRYSTAL TUNING control until the VISUAL CARRIER DEVIATION meter corresponds exactly with the report given by the monitoring service. The AURAL CARRIER DEVIATION meter should then agree very closely with the report of the monitoring service.

A secondary method of correcting the frequency monitor is used when direct contact with the monitoring service is impractical. When the monitoring service report is received, check the transmitter log for the day and time the measurement was made. If the monitoring service report indicates the visual transmitter was 500 cycles high and the log indicates the visual transmitter was 300 cycles high at the same time, the indication is that the Model 335E was in error by 200 cycles. To correct this adjust the CRYSTAL TUNING to raise the present VISUAL CARRIER DEVIATION indication by 200 cycles.

#### Daily Operating Procedure --

1. Turn the POWER switch on at least 30 minutes before air time.

Before the transmitter carriers are put on the air -

2. Check the CRYSTAL TEMPERATURE, it should be  $65^{\circ}\text{C} \pm 3^{\circ}$  (inside green sector).
3. Set the Function Selector to the CALIBRATE position. The AURAL CARRIER DEVIATION meter should indicate exactly zero, if not adjust "C". The PERCENT MODULATION meter should indicate exactly 100%, if not adjust "D".
4. Set the Function Selector switch to the "2" position. The VISUAL CARRIER DEVIATION meter should indicate at least +.5 Kc.
5. Set the Function Selector to the "1" position. The VISUAL CARRIER DEVIATION meter should indicate at least +.5 Kc and the AURAL CARRIER DEVIATION meter should indicate at least +2 Kc.

After the transmitter carriers are on the air -

6. Set the Function Selector on CARRIER LEVEL. The VISUAL CARRIER DEVIATION meter should indicate between +.5 and +1.5 Kc., when the Visual transmitter is transmitting no visual modulation, i. e., a "black" level. Visual modulation will produce a lower indication. The AURAL CARRIER DEVIATION meter should indicate between +2 and +6 Kc.

7. Set Function Selector to USE position.

## Circuit Description

The arrangement and functions of the various circuits which comprise the Model 335E TV Monitor are outlined by the block diagram shown in Fig. 3. The transmitter aural and visual carrier frequencies are separately combined with an accurately controlled frequency derived from a crystal - controlled oscillator in the instrument.

A frequency difference of 150 kc plus or minus the modulation components appear at the output of the aural mixer. The mean frequency of the aural channel is measured by frequency counting circuits. The frequency counter circuits also demodulate the signal. From this demodulated signal the percent of modulation is measured. Audio voltages are provided for measurement of distortion and frequency response characteristics of the transmitter. Provisions are also available for connecting external modulation meters in series with the internal meter.

A frequency difference of 4.35 Mc appears at the output of the visual mixer when the carrier is on assigned frequency. This output is mixed with a 4.3535 Mc crystal controlled oscillator producing a 3.5 kc output frequency. This output is passed through a filter that removes the 15,750 cps horizontal line frequency components in order to avoid the possibility of interaction of this frequency with the visual deviation circuit. The output waveform is squared and the frequency is measured by the frequency counting circuits.

### Detailed Description of Circuits --

Tube V1 is the crystal oscillator tube which generates the basic frequency with which the transmitter frequencies are compared. The crystal is mounted in an oven whose temperature is regulated by means of a mercury column thermostat. The characteristics of this oven are such that the temperature at the crystal varies by considerably less than 1 degree C as a function of time and over an ambient range from +10°C to +45°C.

This master oscillator is a cathode coupled two-stage circuit operating in the 19 to 28 - megacycle region. It has been selected because it allows series - resonant operation of the crystal. The arrangement has the advantage that stray capacities has less effect on the operating frequency than in the case of parallel - resonant crystal operation. A small capacitance C-102 permits adjustment of the oscillator's frequency.

This master oscillator drives a tuned multiplier V2 which feeds into the separate multipliers for the visual (V3A) and aural (V5A) channel of the monitor.

V3A is the visual mixer tube. A signal from the visual transmitter is applied directly to the cathode of V3B. This input impedance matches the impedance of the 50 ohm cable from the visual output of the transmitter. The grid of V3B is driven by the output voltage from the visual frequency multiplier. This signal combines with the signal from the transmitter to give a difference frequency of 4.35 mc in the plate circuit of V3B. The 4.35 mc output of the first visual mixer is then mixed with the output of a 4.3535 mc crystal controlled oscillator. The oscillator (V4B) is cathode coupled to the mixer tube V4A.

The output of V4A is the 3.5 kc difference frequency. This output is passed through a filter which removes the 15,750 cps horizontal line frequency

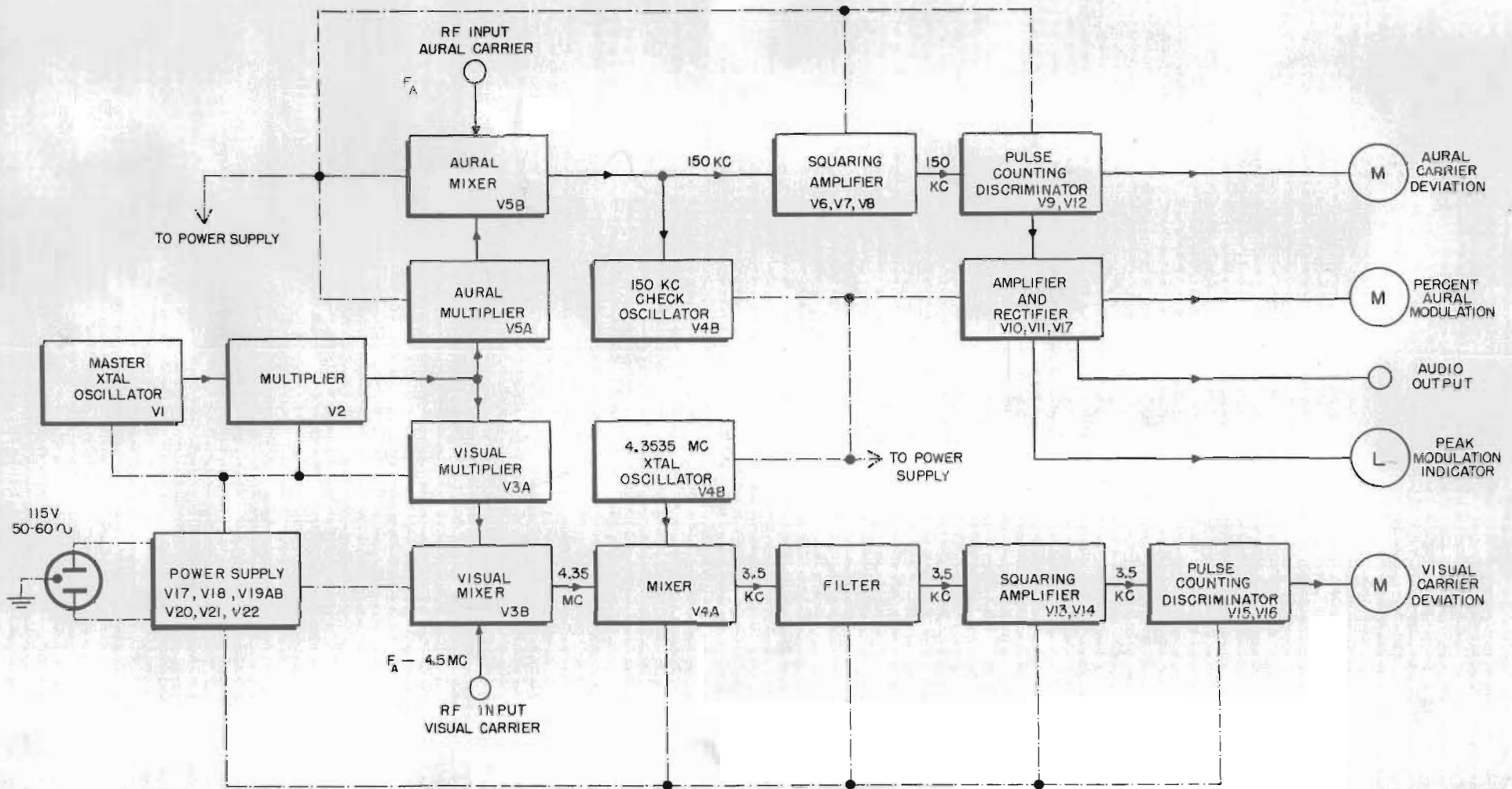

Fig. 3. Model 335E Block Diagram

component before being applied to the squaring amplifier. J1 is provided at the input of the filter so that an external audio voltage may be used to calibrate the frequency counter.

V13 serves as cathode coupled clipper tube to produce a square wave shape.

V14B is a phase inverter which applies the 3.5 kc signal to the grids of V15A and V15B. The plate current of V15A and V15B is derived from a constant current generator tube V16.

The operation of the switching tubes V15A and V15B is as follows: The grid of V15A is driven positively while the grid of V15B is driven to cut off. All of the current from V16 flows through V15A. In this case however, C240 takes all of the current initially, but as the charge of C240 is building up, more of the current flows through R269 until finally C240 is fully charged to a voltage which is exactly equal to the constant current provided by V16 flowing through R269. In this manner a pulse of accurately controlled current flows through C240 for each alternate half cycle. In a similar manner, the switching of V15B generates a pulse of accurately controlled current through C241.

The time constants of the RC network are selected so that the capacitors will become fully charged on each half cycle at the highest frequency to be measured (3.5 kc plus max. carrier deviation).

These charge and discharge current pulses are rectified by means of a bridge rectifier, and the resultant direct current is applied to M1. The average value of the current passing through M1 is a function of frequency or number of pulses per unit time only. This operation makes the response of M1 directly proportional to frequency. In order to balance out the reading that would be obtained on M1 with a 3.5 kc signal, some current is applied in reverse through M1. This current is generated by the voltage drop across R279, part of the cathode resistor of the constant current generator tube.

The sensitivity of this circuit as a frequency meter is directly proportional to the constant current. However, should there be variations in either the constant current or in the characteristics of the tubes, the meter will still read zero center with 3.5 kc applied.

The aural channel is necessarily more elaborate than the visual channel. V5B is the aural mixer tube whose output frequency is 150 kc plus and minus the frequency deviation.

This signal is applied to V7B where it is amplified. When in the calibrate position V4B is connected as a crystal controlled 150 kc oscillator to calibrate the frequency counting circuits. A crystal limiter, CR1 and CR2, is connected to the grid circuit of V6A so that the driving voltage is limited and clipped to provide a square wave shape. V6A and V6B serve as cathode coupled clipper tubes for squaring the 150 kc signal. V7A operates as a phase inverter providing a balanced signal voltage for V8A and V8B. V8A and V8B constitute a squaring amplifier before the signal is applied to the frequency counting current. The pulse counting discriminator (V9, V12) is similar to the counter in the visual channel except that it contains circuitry that acts as a discriminator for the f-m modulation on the aural carrier. The current applied to the deviation meter, M2, consists of a series of



pulses of direct current, the 150 kc components of which are by-passed through C244.

When frequency modulation is applied to this counter circuit, the rectified value of the current varies linearly with frequency deviation. This rectified current generates an audio signal in the primary of transformer T1. V10 serves as an audio amplifier with feedback by means of tertiary winding on T1 so that the response and gain is stabilized. The audio output from V10 is applied to V11B which serves as a cathode follower to provide a distortion free audio output for monitoring and for measuring purposes. The networks and the rectifier which determine the operation of modulation meter, M3, are connected to the cathode circuit of V11A. This circuit is a peak reading voltmeter in which a direct current voltage is generated across C222 proportional in value to the peak value of the audio frequency. Additional networks are provided so that together with the dynamic characteristics of the meter movement the dynamic response characteristic of the modulation meter corresponds to that specified by the F. C. C. The same direct current voltage which operates the modulation meter is fed through R303 to the grid of V17. V17 is a thyratron arranged to flash a lamp when the peak value of audio voltage exceeds a preset level which is controlled by R312 in the cathode circuit of V11. This preset value may be regulated from 50 to 120% modulation.

The power supply provides a 300 volts regulated direct current source. Hum reduction is improved by V22 which is sensitive to AC but not DC voltage components.

Transformer T3 supplies a regulated voltage to the heaters of the oscillator and mixer tubes.

## Maintenance

### Case Removal --

The case can be removed satisfactorily while the instrument is in the rack. However, very little if any work can be performed on the instrument while it is in the rack. Therefore, the instrument should be removed from the rack whenever maintenance work is necessary.

Place the instrument, control panel side down, on a flat surface and remove the two screws next to the rectangular opening in the back of the case. Pull the case away from the control panel.

To replace the case reverse the above procedure being careful to guide the fan plug into the receptacle on the chassis.

### Air Filter Maintenance --

The air filter should be cleaned periodically. In some locations cleaning may be necessary every two weeks but in most cases less frequent cleaning will be required.

The filter is mounted in the back of the case so that one half of the filter area is in use. When one half of the filter becomes dirty, the filter unit may be turned so that the clean half is in use.

The procedure for cleaning the filter is as follows:

1. Remove surface loaded lint and large particles from the air filter by vacuuming or gently tapping the filter with the dirty side down.
2. Direct a stream of water, preferably hot, from a hose or faucet at each side of the filter to flush out the old adhesive and accumulated dirt.
3. Shake out excess water and allow to dry.
4. Apply Filter Coat No. 3 with the HANDIKOTER spray directed at (Intake) side of filter until visible baffles are liberally coated.

### WARNING

Do not spray to the extent that adhesive runs off surface or drips. Excessive adhesive may be drawn into the instrument by the fan.

5. Filter is now ready for service.

### Meter Lamp Replacement --

The two lamps that illuminate each meter may be replaced by unscrewing the two screws on the front of the meter and pulling the meter case away from the control panel. The lamps inside of the meter case may then be removed and

replaced with new lamps. Replace the meter case on the control panel and tighten the two mounting screws.

### Tube Replacement --

Whenever a tube is replaced, the following table should be consulted to determine whether or not the characteristics of the replacement tube will necessitate circuit adjustments. The procedures for performing these adjustments will be found in the Circuit Adjustments section.

### TUBE REPLACEMENT TABLE

<u>Tube</u>	<u>Function</u>	<u>Required Circuit Adjustments</u>
V1	Master Oscillator	Check master oscillator frequency.
V2	Frequency Multiplier	Check multiplier tuning.
V3 ✓	Frequency Multiplier Visual Mixer	Check multiplier tuning.
V4 ✓	150 kc Oscillator 4.3535 mc Oscillator Visual Mixer	{ Not critical; 150 kc oscillator activity indicated on visual meter, calibrate. { 4.3535 mc oscillator activity indicated on visual meter, Tune 2.
V5	Frequency Multiplier Aural Mixer	Check multiplier tuning.
V6 ✓	Amplifier	Not critical.
V7	Amplifier	Not critical.
V8	Amplifier	Not critical.
V9	Switching Tube	Reset controls C and D.
V10	Amplifier	{ May have to select for minimum hum. { May have to select for minimum distortion.
V11 ✓	Cathode follower	Same as V10.
V12 ✓	Constant Current Generator	Reset controls C and D.
V13 ✓	Amplifier	Not critical.
V14 ✓	Amplifier	Not critical.
V15 ✓	Switching Tube	Reset controls A and B.
V16 ✓	Constant Current Generator	Reset controls A and B.

<u>Tube</u>	<u>Function</u>	<u>Required Circuit Adjustments</u>
V17	Peak Indicator Trigger	Check calibration of 50% - 120% control against modulation meter and reset if necessary.
V18	Xtal Oven Heater Control	Not critical.
V19	Series Regulator	Not critical.
V20	Amplifier	Reset high voltage regulator to 300 volts.
V21	Voltage reference	Reset high voltage regulator to 300 volts, Reset controls B and D.
V22 ✓	Amplifier	Not critical

#### Circuit Adjustments and Maintenance Procedure --

In addition to the external adjustments, inside the instrument cabinet there are a number of controls which may require adjustment occasionally due to tube aging or tube replacement. The procedure for making these adjustments will be broken into four main circuit sections:

- A. R.F. section (tubes V1, V2, V3, V4, V5, V7B)
- B. Aural counter section (tubes V6, V7A, V8, V9, V10, V11, V12)
- C. Visual counter section (tubes V13, V14, V15, V16)
- D. Power supply and crystal oven control circuit (tubes V17, V18, V19, V20, V21, V22)

#### NOTE

Whenever the instrument is removed from the relay rack for circuit adjustment or maintenance, the instrument should be connected to the power line so that the crystal ovens will remain at operating temperature.

#### A. R.F. Section

1. Master oscillator - tube V1

(See Fig. 4 for the location of the adjustments.)

C104 - This variable capacitor is the coarse frequency control. It is in parallel with C102, the front panel CRYSTAL TUNING fine frequency control. This control will normally be adjusted only when:

- a. Changing tube V1
- b. Frequency drifts beyond range of CRYSTAL TUNING control
- c. Changing quartz crystal

In TUNE 1 position, the modulation meter is connected to indicate the drive from the local oscillator to the first multiplier. The proper frequency will be obtained somewhere near the point of maximum drive.

Caution should be observed in adjusting C104. The high frequency crystals used have a number of modes at which they will oscillate, and it may be possible by changing C104 too far to get the crystal to oscillate in one of these spurious modes which will be at the wrong frequency. A minimum adjustment should be made. (See also section on master oscillator frequency measurement.)

L20 - This is a variable inductance which adjusts the output impedance of the master oscillator for maximum drive into the input capacity of the first multiplier, V2. This control will seldom need adjustment. It may be checked when V2 is replaced. In TUNE 1 position, the deviation meters are adjusted to indicate the grid current of the respective mixers. L20 should be adjusted in this position for maximum indication on these meters.

## 2. Multiplier - tube V2

C113 - This capacitor resonates with inductance L2 to select the desired harmonic multiplication in V2. It may be necessary to adjust C113 when replacing V2. Adjust C113 for maximum indication on either deviation meter in TUNE 1 position. Since it may be possible to adjust C113 far enough to obtain the wrong harmonic, a minimum adjustment should be made. The L2, C113 tank is tuned to two times the master crystal frequency for channels 2, and 6 through 83. (See first page of instruction book for crystal frequency.) It is tuned to three times the crystal frequency for channels 3, 4, and 5. This frequency may be checked at L2 with a grid dip meter if desired.

## 3. Aural Multiplier - tube V5

C135 - This capacitor resonates with inductance L9 to select the proper harmonic frequency of multiplier V5. It may be necessary to retune C135 after replacing V5. Adjust C135 for maximum indication on the aural deviation meter in TUNE 1 position. This tank circuit operates at the following crystal harmonic:

Channel 2	Second harmonic
3, 4, 5	Third harmonic
6 - 83	Fourth harmonic

This frequency may be checked at L9 with a grid dip meter if desired.

## 4. Visual multiplier and mixer - tube V3

C116 - This capacitor resonates with inductance L3 to select the proper harmonic frequency of multiplier V3. It may be necessary to retune C116 after replacing V3. Adjust C116 for maximum indication on the visual deviation meter in TUNE 1 position. This tank circuit operates at the following crystal harmonic:

Channel 2	Second harmonic
3, 4, 5	Third harmonic
6 - 83	Fourth harmonic

This frequency may be checked at L3 with a grid dip meter if desired.

355E 1/27/54 SERIAL 1 AND ABOVE

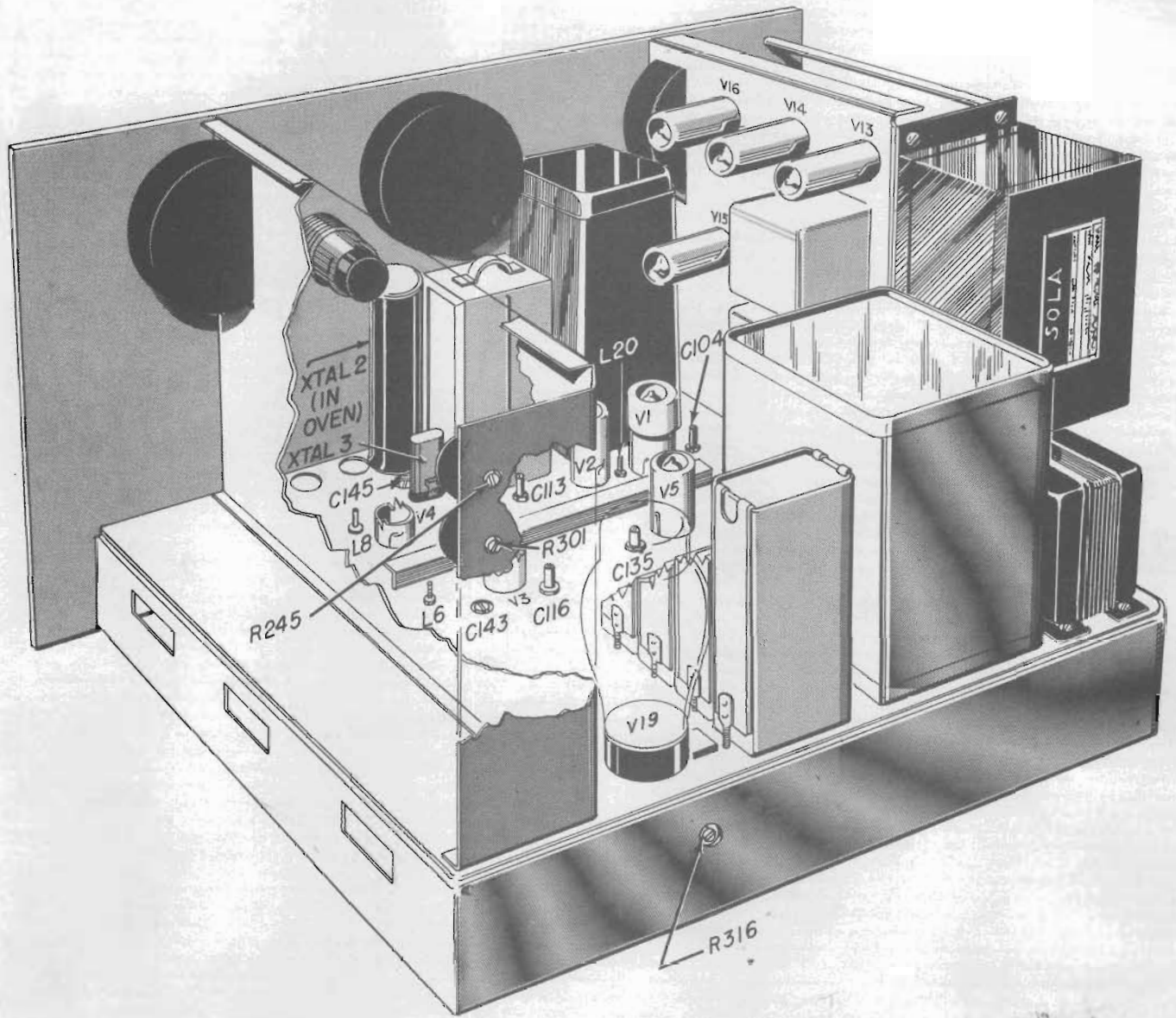

Fig. 4. Model 335E Location of Adjustment Controls

L6 - This inductance resonates with the output capacity of V3 and the input capacity of V4 at 4.35 mc, the output frequency of V3. This control will seldom need to be adjusted. It is adjusted in USE position with the visual transmitter r.f. input connected. With an oscilloscope connected at pin 2 of V14, adjust L6 for maximum 3.5 kc signal.

5. 4.3535 mc oscillator and mixer; 150 kc oscillator - tube V4

C143 - This small variable capacitor injects a certain amount of the r.f. input signal on the mixer grid of V3. This provides greater conversion gain for the higher r.f. input frequencies. In instruments on channels 2 to 13, it will have little effect. It may be necessary to readjust C143 when changing V3. Adjust C143 in the USE position with the visual transmitter input connected. With an oscilloscope connected to pin 2 of V14, adjust C143 for maximum 3.5 kc signal.

C145 - This capacitor provides adjustment of the 4.3535 mc oscillator which beats with the 4.35 mc signal from the V3 visual mixer to produce the 3.5 kc intermediate frequency for the visual counter. This control will seldom need to be adjusted - only occasionally to compensate for long time drift of the 4.3535 mc crystal.

To determine whether or not the 4.3535 mc oscillator has drifted and needs adjusting, refer to the block diagram of the instrument, Figure 3. Assume that both visual and aural counter circuits have been calibrated, i. e., the aural counter circuit indicates zero deviation for 150 kc i. f., and the visual counter reads zero deviation for 3.5 kc i. f. (See procedure for adjusting A, B, C, D controls). From the block diagram it will be seen that the only factors determining the reading of the aural deviation meter are the frequencies of the aural transmitter and the master crystal oscillator frequency. If a frequency check on the transmitter is made, the CRYSTAL TUNING control should be adjusted to make the aural deviation meter indicate the known frequency error of the aural transmitter. The visual deviation meter should then indicate the same frequency error as that which the visual transmitter is measured to have. If it does not indicate this frequency correctly, the 4.3535 mc crystal frequency is incorrect. Since this 4.3535 oscillator is quite stable, the measurements of the visual and aural transmitter frequencies should be known positively to be correct before adjusting C145, unless the 4.3535 mc frequency can be measured directly. The direct method is to connect a frequency counter, or other accurate frequency measuring device to pin 3 of V4. Adjust C145 for exactly 4.3535 mc.

L8 - This inductance resonates with C146 and the output capacity of V4 to form the plate tank of the 4.3535 mc oscillator. L8 will not often require adjustment unless the 4.3535 mc crystal is replaced. L8 is adjusted so that in TUNE 2 position (in which the visual deviation meter indicates the activity of the 4.3535 mc oscillator) the activity is about 25% below maximum activity on the high frequency side of maximum activity. To set, turn adjusting slug of L8 until as much as possible of the screw extends above the chassis. Next, watching the visual deviation meter in TUNE 2, turn the screw back in until maximum activity is reached. Then back out until the meter indicates about 25% drop in activity. Note: since this adjustment affects the 4.3535 mc frequency, C145 must be adjusted if L8 is adjusted.

335E 1/22/54 Serial 1 and above

150 kc crystal - In CALIBRATE position the right half of V4 is connected as a 150 kc oscillator to calibrate the aural deviation meter. The grid of V4 is connected to a 150 kc crystal. The visual deviation meter indicates the oscillator activity. The plate tank of this oscillator is L7 in parallel with C129 and C130. There are no adjustments on this frequency. The frequency of this oscillator may be checked with a frequency counter at pin 3 of V4, or at terminal 6 of the back lip terminal board. This measurement must be made in CALIBRATE position. A new crystal should be obtained if frequency is not 150 kc  $\pm$  50 cps.

## B. Aural Counter Section

### 1. Deviation meter and modulation meter calibration

C - This front panel adjustment controls the amount of current applied to the aural deviation meter to offset the zero point 150 kc, so that the meter reads zero deviation with a 150 kc i. f. Adjust "C" in CALIBRATE position for zero deviation on the aural deviation meter.

D - This front panel control adjusts the constant current in V12 which is applied to the switching tube V9. The amount of this current determines the full scale sensitivity of the aural deviation meter and the full scale sensitivity of the modulation meter. In the CALIBRATE position, the modulation meter indicates the constant current level. The sensitivity of the modulation meter has been adjusted at the factory so that the correct constant current will read 100%. "D" should be adjusted in CALIBRATE for 100% on the modulation meter.

R244 - This control, on the back lip, has been set at the factory to adjust the modulation meter sensitivity in CALIBRATE so that it reads 100% with the correct constant current. This control should only be moved when calibrating the modulation meter. To calibrate the modulation meter, proceed as follows:

1. Set a known percent modulation, preferably between 100 cps and 1 kc on the aural transmitter using the null method as described in this book.
2. In USE position, adjust "D" control to make modulation meter read the known percent modulation.
3. In CALIBRATE position, adjust R244 to make modulation meter read 100%.

### 2. Peak Modulation Indicator

50-100% - This front panel control adjusts the bias voltage of V17, the grid controlled thyatron. When the grid voltage, which is proportional to the percent modulation, exceeds the bias voltage, the tube fires and flashes the lamp. To calibrate this control, apply a steady modulation to the aural transmitter. Read the percent modulation on the modulation meter. If necessary, loosen the set screws on the 50-100% control knob, and slip knob so that the lamp fires at the indicated meter percentage.



### 3. Audio Amplifier - tubes V10, V11

Any distortion that is introduced in the audio output of the aural monitor is most likely to be caused by bad tubes in either V10 or V11 circuits. Provision has been made to check the distortion of the audio section alone. At the very front of the aural counter deck below resistor board RB7 (see photograph Figure 9) is a two point terminal board. The orange leads are electrically in series with C213; the gray leads in series with the lead on the schematic going between C216 and R246. To measure distortion in the amplifiers, loosen the terminal screws and pull away the spade lug leads. Connect a jumper from the gray lead terminal point to ground. Connect one end of a 5,000 ohm resistor to the orange lead terminal point. Connect a low distortion audio oscillator between the other resistor end and ground. Connect distortion analyzer between terminals 4 and 5 on back terminal board. Adjust oscillator voltage to make modulation meter, in USE position, read 100%. This will require about one volt. Measure distortion at output terminals. It may be necessary to try several tubes to obtain low hum and low distortion. See also section 4 below.

### 4. Hum Bucking Potentiometer

R301 - This control on the back of the aural deck is a center tapped potentiometer connected across the heater voltage of the audio amplifier tubes, V10 and V11. It is adjusted for minimum hum in the high impedance output, terminals 4 and 5 on the back terminal board in CALIBRATE position. Although this control will reduce hum with almost any tube complement, it will not compensate entirely for tubes with high hum, particularly in V10 and V11 circuits.

## C. Visual Counter Section

### 1. Deviation meter calibration

A - This front panel control adjusts the amount of current applied to the aural deviation meter to offset the zero point 3.5 kc, so that the meter indicates zero deviation with a 3.5 kc i.f. To calibrate this meter and counter circuits it is necessary to provide a 3.5 kc signal. Connect an audio oscillator to a phone plug inserted in jack J1 on the front panel. Set switch to USE position. Set oscillator to 3.5 kc, level about one volt. Adjust "A" for zero deviation. Note that any inaccuracy in the oscillator frequency will be reflected in the calibration.

B - This front panel control adjusts the constant current in V16 which is applied to the switching tube V15. The amount of this current determines the full scale sensitivity of the deviation meter. With the external oscillator connected as before for setting "A", adjust oscillator frequency to 5 kc. Adjust "B" to read +1.5 kc. Reset oscillator to 2 kc. Between 2 and 5 kc input frequency, adjust "B" for optimum accuracy at +1.5 kc and -1.5 kc. As was noted before, the accuracy of this calibration is determined by the oscillator frequency accuracy.

## D. Power Supply and Crystal Oven Heater Control Circuit

### 1. 300 volt regulated supply

This supply consists of a standard d.c. regulator consisting of tube V19, 20, 21 plus an a.c. amplifier tube V22 to reduce the output ripple voltage and

lower the a. c. internal impedance. In USE position, the B+ ripple voltage as measured at pin 1 of V11 should be less than 0.003 volts with no r. f. signals applied to the monitor.

R316 - This control, on the back lip of the instrument, is used to adjust the regulated voltage to +300 volts. This voltage can be measured at pin 1 of V11. This voltage should be +300 volts at any position of the CARRIER LEVEL-CALIBRATE switch at a line voltage of 115  $\pm$  10% volts. Poor regulation is most likely to be caused by a bad tube - V19, 20, 21 low voltage from bridge rectifiers; or excessive current drain due to component failure in instrument.

## 2. Crystal oven heater control circuit

Tube V18 and its associated circuitry are used to operate the master oscillator crystal oven temperature control. The use of a vacuum tube reduces the current through the sensitive contacting mercury thermostat, thus greatly lengthening its life. The relay must be energized for power to be applied to the crystal oven heater. This prevents overheating and consequent damage to the quartz crystal on failure of most of the circuit components.

### Measurement of Master Oscillator Frequency --

The measurement of frequency variation of the aural and visual transmitters is based entirely on the determination of the difference frequency between the transmitters and a harmonic of the internal crystal oscillator. Therefore the accuracy of this frequency measurement is dependent on the accuracy and the stability of the master oscillator and the frequency counting circuits.

It will be necessary to check the master oscillator frequency whenever the power has been disconnected from the unit, allowing the master crystal oven to become cold. It is possible, and quite often found, that even stable quartz crystals will not come back on frequency exactly after cooling and reheating. Severe shock and vibration, such as encountered in shipping, or accidental dropping, will also require a frequency check. And periodic frequency checks should be made to allow compensation of frequency drift.

Before checking the master oscillator frequency, it is imperative that the power line has been connected for 24 hours to allow the oven and crystal to temperature stabilize, and the instrument turned ON at least one hour.

There are two methods of frequency measurement - direct and indirect.

1. In the direct method the frequency of the master oscillator or one of its harmonics is measured directly with a frequency counter. A Hewlett-Packard 524B Frequency Counter, or equivalent, should be used. The counter should be capable of measuring frequencies to 60 mc. The easiest place to obtain this signal is at the aural r. f. input jack. In USE position the following harmonics of the master crystal oscillator frequency will be found at this jack:

Channel 2	Second harmonic
3, 4, 5	Third harmonic
6 - 83	Second and Fourth harmonic

335E 1/22/54 Serial Hand above

The correct crystal oscillator frequency is given on the first page of the instruction book.

Since the accuracy of a frequency counter depends on the crystal oscillator frequency which is divided down to determine the gate time, for maximum accuracy the frequency counter crystal frequency should be set against a secondary standard or station WWV. Most counters use crystals at 100 kc, or some multiple of 100 kc. To compare with station WWV, couple a small amount of the 100 kc (or other) frequency into the antenna terminals of a radio receiver tuned to one of station WWV's standard frequencies. One of the harmonics of the 100 kc signal will beat with the WWV signal to provide an audio note which may be brought to zero beat by adjusting the 100 kc frequency control. Human hearing will not distinguish a very low frequency beat note. However, the "S" meter, if the receiver has one, may be used to determine beat notes of one cycle per second or less. Watch "S" meter for a slow beat note after the audio beat has dropped below hearing range. It may be necessary to adjust the coupling of the signal from the frequency counter so that the desired harmonic is about equal in amplitude to the WWV signal. Frequency measurements with an accuracy of one part in ten million are readily made with this technique.

2. The indirect method of frequency measurement utilizes a frequency check on the transmitter by a separate monitoring service - usually at a remote location. At any moment, the monitor should indicate the frequency error, as reported, of the two transmitters. If it does not, it should be recalibrated.

The procedure is as follows:

a. Calibrate the visual and aural counters, i.e. adjust controls A, B, C, D. The visual meter will now read zero deviation for a 3.5 kc i.f.; the aural deviation meter will read zero for a 150 kc i.f.

b. From the monitoring service, obtain a frequency check on the aural transmitter. Set the CRYSTAL TUNING control so that the aural deviation meter indicates the frequency error of the transmitter as obtained from the monitoring service. (Example: if monitoring service says transmitter is 400 cps high, adjust CRYSTAL TUNING control so aural deviation meter reads +0.4 kc.)

c. From monitoring service, obtain a frequency check on the visual transmitter. The visual deviation meter should indicate any frequency error correctly. If it does not, the 4,3535 mc oscillator frequency control, C145, needs adjustment. See section on C145. When using the indirect method, it is preferable to have telephone contact with the monitoring service, so that no frequency drift of the monitor and the transmitter does occur between the time the measurement is completed and the corrections made.

Measurements of Percent Modulation on Aural Transmitter by the Carrier Null Method --

To calibrate the modulation meter, a separate fundamental method of measuring frequency swing must be employed. The percent modulation of the FM transmitter may be measured conveniently by the carrier null method using the IF signal from the monitor. Terminal 6 on the rear terminal board supplies a small IF signal which is centered about 150 kc in frequency and contains the full FM swing of the transmitter. This output should be connected to the antenna terminal of a communication type receiver, preferably one which will tune to 150 kc. However the signal is in the form of a pulse, so that the second and third harmonics can be used.

To start, the transmitter should be unmodulated and the receiver tuned to 150 kc. Adjust the BFO to give a beat note of a few hundred cycles. As sine wave modulation is gradually applied to the transmitter, the amplitude of the transmitter carrier, and hence the receiver beat note, will go through successive amplitude nulls. It is possible to determine the frequency swing, or percent modulation, by adjusting the modulation voltage for a certain null, knowing the modulating frequency. When this null is obtained

$$\text{Frequency swing} = \frac{(\text{Modulation index}) \times (\text{Modulating frequency})}{1}$$

The modulation index depends on which particular null is chosen, and is equal to the argument of the zero order Bessel function when the function has zero value. These values of modulation indices are given in the following table. For higher numbers, the values are spaced at intervals of pi (3.1416).

<u>NULL NO.</u>	<u>MOD INDEX</u>
1	2.405
2	5.520
3	8.654
4	11.792
5	14.931
6	18.071
7	21.212
8	24.353
9	27.494
10	30.635

For television FM, 25 kc frequency swing has been chosen as 100% modulation. We may therefore rewrite the previous equation in terms of percent modulation.

$$\% \text{ MODULATION} = \frac{(\text{MODULATION INDEX}) \times (\text{MODULATING FREQ.}) \times 100}{25,000}$$

where the modulating frequency is in cycles per second.

Example: with no modulation on the transmitter, the receiver has been tuned to 150 kc and BFO adjusted for a few hundred cycles beat note. 4,000 cps

335E 1/22/54 Serial 1 and above

sinusoidal modulation is applied gradually. The amplitude of the beat note decreases, goes through a null, rises, decreases, and comes to a second null. What is the percent modulation?

$$\begin{aligned}\% \text{ modulation} &= \frac{5.520 \times 4000 \times 100}{25,000} \\ &= 88.4\%\end{aligned}$$

If the receiver is tuned to 150 kc, a modulation swing of 25 kc is used for 100% modulation. However if the receiver is tuned to a harmonic, say 450 kc for the third harmonic, the modulation swing is also multiplied by three so that the percent modulation as calculated above should be divided by three.

It should be noted that the accuracy of measurement of modulation percentage cannot exceed the accuracy of the calibration of the modulation frequency. Also it is necessary that the modulation signal have low distortion if the nulls are to be sharply indicated.

Refer to the paragraph on the adjustment of R244 in the Maintenance Section for the procedure for calibrating the modulation meter.

#### Measurements of Incidental Amplitude Modulation on Aural Carrier --

A special jack is provided on the -hp- TV Monitor to facilitate the measurement of spurious amplitude modulation on the aural carrier. This jack is located on the back of the instrument and is marked J5. Measurements of spurious AM modulation can be made at this jack with sensitive DC and AC voltmeters in the following described manner. It is not necessary that the monitor be turned on for this test, since only germanium diodes in the input circuit are used.

1. With the function selector in CARRIER LEVEL position, measure the DC voltage across a phone plug inserted into J5 with a vacuum tube voltmeter. This voltage will be between about 0.1 volt and 3 volts. Record this reading.
2. Replace the DC voltmeter with a sensitive AC voltmeter, such as the -hp- 400 A, B, C, D or the voltmeter section of an -hp- 330B, C, D Distortion Analyzer. Read and record this AC voltage.
3. The percentage of amplitude modulation may then be obtained with the following formula:

$$\% \text{ AM} = \frac{141.4 (\text{AC voltage})}{\text{DC Voltage}}$$

Example: The DC voltage measured 1.78 volts. The AC voltage measured 0.0013 volts.

$$\begin{aligned}\% \text{ AM} &= \frac{141.4 \times 0.0028}{1.78} \\ &= 0.21\%\end{aligned}$$

In some cases, the input voltage requirement of the 335E may be so low that difficulty may be found in measuring these voltages because of their low level. In this case it is permissible to readjust the coupling probe that samples the aural transmitter output so that a DC level of up to, but not more than, three volts is obtained. After measuring the percent AM, the probe should be returned to its previous position as indicated on the aural deviation meter in CARRIER LEVEL position.

#### Noise Generated in Aural Monitor --

The noise generated in the Model 335E is at least 60 db below the audio output level resulting from 100% modulation at low frequencies. Assuming that 100% modulation at a low frequency provides exactly 10 volts output at the high-impedance audio output of the Model 335E, the noise as measured across a 100,000 ohm (minimum) load on terminals 4 and 5 should be not more than 10 millivolts.

Noise should be measured with the switch in the "CALIBRATE" position. In no case should noise be measured by removing the RF input from the monitor with the switch in the "USE" position, nor should the noise be measured by shorting the RF input. When the RF is removed with the switch in the "USE" position, the monitor operates with the equivalent of a floating grid circuit causing an increase in the noise level.

335E J1/22/54 Serial 1 and above

Trouble Shooting --

A great amount of time can be saved in trouble shooting the Model 335E TV Monitor if (1) the frequency of the master oscillator in the monitor, the visual transmitter frequency, and the aural transmitter frequency are ac-  
curately known; and (2) judicious use of the meter indications of the front panel meters is made as they are switched into various circuits with the Function Selector Switch.

The following check list of possible indicated troubles will help in narrowing down the area in which a fault may be expected.

Symptoms

A. Visual deviation meter indicating properly; aural deviation meter erratic or off scale.

Test Procedure

1. Check input level from aural transmitter in CARRIER LEVEL.
2. Check aural deviation meter in CALIBRATE - it should indicate zero deviation; if it does not, check:
  - a. Visual deviation meter in CALIBRATE to see that 150 kc oscillator is operating; if not, check V4.
  - b. Observe signal with oscilloscope at pin 6, V7 in CALIBRATE. Should be 150 kc sine wave, over five volts r. m. s.
  - c. Check tubes and circuits of V6, V7, V8, V9, V12. Waveform should become more square at each succeeding tube plate. Approximate peak to peak square wave amplitudes are:
 

V6	pin 1	16 volts
V7	pin 1, 3	15 volts
V8	pin 1, 9	16 volts
V9	pin 1, 9	42 volts
  - d. Check crystal bridge CR3. May be interchanged with CR6.
3. Check frequency of aural transmitter.
4. Check frequencies of master oscillator and visual transmitter - both may be off.

## Trouble Shooting (Continued)

### Symptoms

- B. Aural deviation meter indicates properly; modulation meter working; visual deviation meter erratic or off scale.

### Test Procedure

5. Check level of 150 kc signal at pin 6, V7 in USE position; should be over three volts rms. If too low, check:
  - a. Grid current of aural mixer, as indicated on aural deviation meter in TUNE 1 - should indicate between +2 kc and +6 kc. If too low check V2 and V5, tuning of C113 and C135.
6. Check B+ voltage in USE position; should be 300 volts.
  1. Check input level from visual transmitter in CARRIER LEVEL,
  2. Connect audio oscillator to J1 as described in procedure for adjusting controls "A" and "B" in Maintenance Section of this manual. Check calibration and sensitivity in USE position. Meter should indicate accurately with input levels of 0.3 volts to 10 volts rms. If it does not operate correctly at these levels, check:
    - a. Tubes and circuits of V13, V14, V15, V16. With one volt, 3.5 kc input at J1, waveform at each succeeding plate should be more square. At V15 pin 1, 9 square wave should be about 48 volts peak to peak.
    - b. Check 300 volts B+ in USE position.
    - c. Check crystal bridge CR6. May be interchanged with CR3.
  3. Check signal at output of V4 mixer with oscilloscope to see if it is approximately correct frequency (2 to 5 kc) and proper level (over 0.5 volts rms.) This may be checked with the monitor in the cabinet by inserting a phone plug into J1 just far enough so that the tip of the phone plug touches the center contact of the jack, but not far enough to open the circuit. Connect oscilloscope across phone plug. In addition to the desired 3.5 kc signal, much of the modulation on the visual transmitter will also be seen. It will simplify analyzing the observed pattern if this test is performed at a time when the visual transmitter modulation may be removed. If level is too low, see paragraph 4. If frequency is wrong, see paragraph 5.
  4. If level of output signal of V4 mixer, as measured in paragraph 3 is too low, check:



Trouble Shooting (Continued)SymptomsTest Procedure

- a. Grid current of visual mixer, V3, as indicated in TUNE 1 visual deviation meter should indicate between +0.5 kc and +1.5 kc with no r.f. input from the transmitter. If too low, check V2 and V3, tuning of C113 and C116.
  - b. If V3 mixer grid current is correct, as checked in (a) above, switch to TUNE 2. The visual deviation meter indicates the 4.3535 mc oscillator activity; meter should read between +0.5 kc and +1.5 kc. If it does not, check V4.
5. If frequency of output signal of V4 mixer, in paragraph 3, is not between 2 kc and 5 kc, check:
- a. Frequency of visual transmitter.
  - b. Frequency of master oscillator and aural transmitter - both could be off.
  - c. Frequency of 4.3535 mc oscillator. See paragraph on adjustment of C145 in Maintenance Section.
- C. Aural deviation meter indicates properly; modulation meter erratic; reads high with no modulation; high noise in audio output at back terminal strip.
1. Check rf input in CARRIER LEVEL position, should indicate between +2 kc and +6 kc on aural deviation meter.
  2. Check noise at audio output, terminals 4 and 5 on back terminal strip, in CALIBRATE position. Noise should be less than 0.010 volts rms. If not, check:
    - a. Grid current of 150 kc oscillator as indicated on visual deviation meter in CALIBRATE position. Should read between +0.5 kc and +1.5 kc. If not, check tube V4.
    - b. Check B+ 300 voltage in USE and CALIBRATE position, check hum on regulated voltage. See paragraph C1 of Maintenance Section.
    - c. 150 kc signal level at pin 6, V7 in CALIBRATE. Should be at least five volts rms.

## Trouble Shooting (Continued)

### Symptoms

### Test Procedure

- d. Check squaring operation of limiter tubes as described in paragraph A, 2 above. Proper limiting operation is essential for low noise performance. Check limiting in both CALIBRATE position and USE position with no modulation on aural transmitter.
- e. If hum or noise still is obtained at the audio output in CALIBRATE, check circuits of V10 and V11 by method described in B3 in Maintenance Section. This procedure can be used for checking noise by reducing the audio input signal to zero.
- D. Audio output voltage normal; modulation meter not functioning.
1. Check V11 tube and circuit. *also V10 tube & circuit,*
  2. Check that 1000 ohm dummy meter resistor R271 is connected.
  3. Check diodes CR4 and CR5.
- E. Modulation meter operating normally; peak modulation indicator not operating.
1. Check tube V17.
  2. Check lamp I1.
  3. Check D.C. voltage at pin 1 V17. Should be approximately ten volts for 80% modulation.
- F. Temperature of master oscillator crystal oven (as indicated on thermometer) too low.
1. Check fuse F2 on back lip. Replace if necessary, with one-half ampere, "Slo-Blo."
  2. Check tube V18.
  3. Check voltage across C303.
  4. Check mercury thermostat in crystal oven. See section on crystal oven removal.
- G. Temperature of master oscillator crystal oven too hot.
1. Check Relay 1 to see if it is stuck in energized position.
  2. Check mercury thermostat in crystal oven. See section on crystal oven removal.

## Master Oscillator Crystal Oven Disassembly and Maintenance --

Occasionally it may be necessary to disassemble the master oscillator crystal oven, either to change the quartz crystal or for servicing the oven. The procedure outlined below should be followed.

The temperature of the oven is regulated by a mercury column thermostat which closes when the oven reaches operating temperature. When this thermostat, in the control grid circuit of tube V18 closes, it biases V18 to cut-off, de-energizing the plate relay which disconnects the oven heater power. The reverse operation occurs when the oven temperature drops to a point at which the thermostat opens. Note that tube V18 must be conducting and the relay energized for the oven to heat. Therefore normal failures of the tube and relay will not cause the oven to overheat with possible consequent damage to crystal. As a further protection against high temperatures, a second bi-metallic thermostat is inside the crystal oven which is directly in series with the heater winding. It is normally closed, but will open at about 75°C, ten degrees above the normal operating temperature.

If the crystal oven does not heat, check fuse F2, tube V18, and relay REL 1. If the oven overheats, remove crystal oven top and check mercury thermostat.

Occasionally the mercury column is separated by jarring and vibration of the unit in shipping. After turning on the instrument for the first time, keep a close check on the temperature of the crystal oven as indicated on the front panel thermometer. When the oven has been on about thirty minutes, the crystal oven should remain automatically at a constant temperature. The thermometer should indicate  $65^{\circ}\text{C} \pm 3^{\circ}\text{C}$  (or inside green sector). However, if the temperature goes beyond  $70^{\circ}\text{C}$  (or outside green sector), the mercury column has probably been separated.

The procedure for oven disassembly is as follows:

1. Disconnect power cord.
2. Remove front panel thermometer. See figure 4A.
3. Remove four 6-32 nuts (or screws) which hold oven top. See figure 4B.
4. Lift off oven top.

The quartz crystal will now be accessible.

To check the mercury thermostat:

5. On the oven top, remove the two 6-32 screws which hold the three contact terminal block. See figure 4A.
6. Pulling gently and steadily on the lead wires, pull out the mercury thermostat.

7. Remove insulating tape and inspect the thermostat for mercury column separation and minute gas bubbles in the mercury bulb.
8. If either bubbles or separation are present, place the mercury bulb in ice water until the mercury occupies only the bulb compartment. Tap lightly to remove any bubbles or mercury globules left in the column. Then place the bulb in a container of water and heat until mercury completely fills column and a small portion of the enlargement at top of column. Then remove the thermostat and watch the mercury descend to room temperature. If there is no separation or bubble present, the thermostat may now be put back in service. It may be necessary to repeat the above procedure more than once to unite all the mercury and remove all bubbles.

CAUTION: Immerse only the bulb portion of the thermostat. If the thermostat leads get wet or any moisture collects beneath the plastic insulation covering the contact rings, dry tube and leads thoroughly before placing back in service. Otherwise leakage between leads may cause heater relay to remain open.

Re-assemble oven in reverse procedure. It will be necessary to check the master oscillator frequency after oven temperature has been stabilized for 24 hours. See "Measurement of Master Oscillator Frequency" section for proper procedure.

335E, 1/22/54 Serial 1 and above

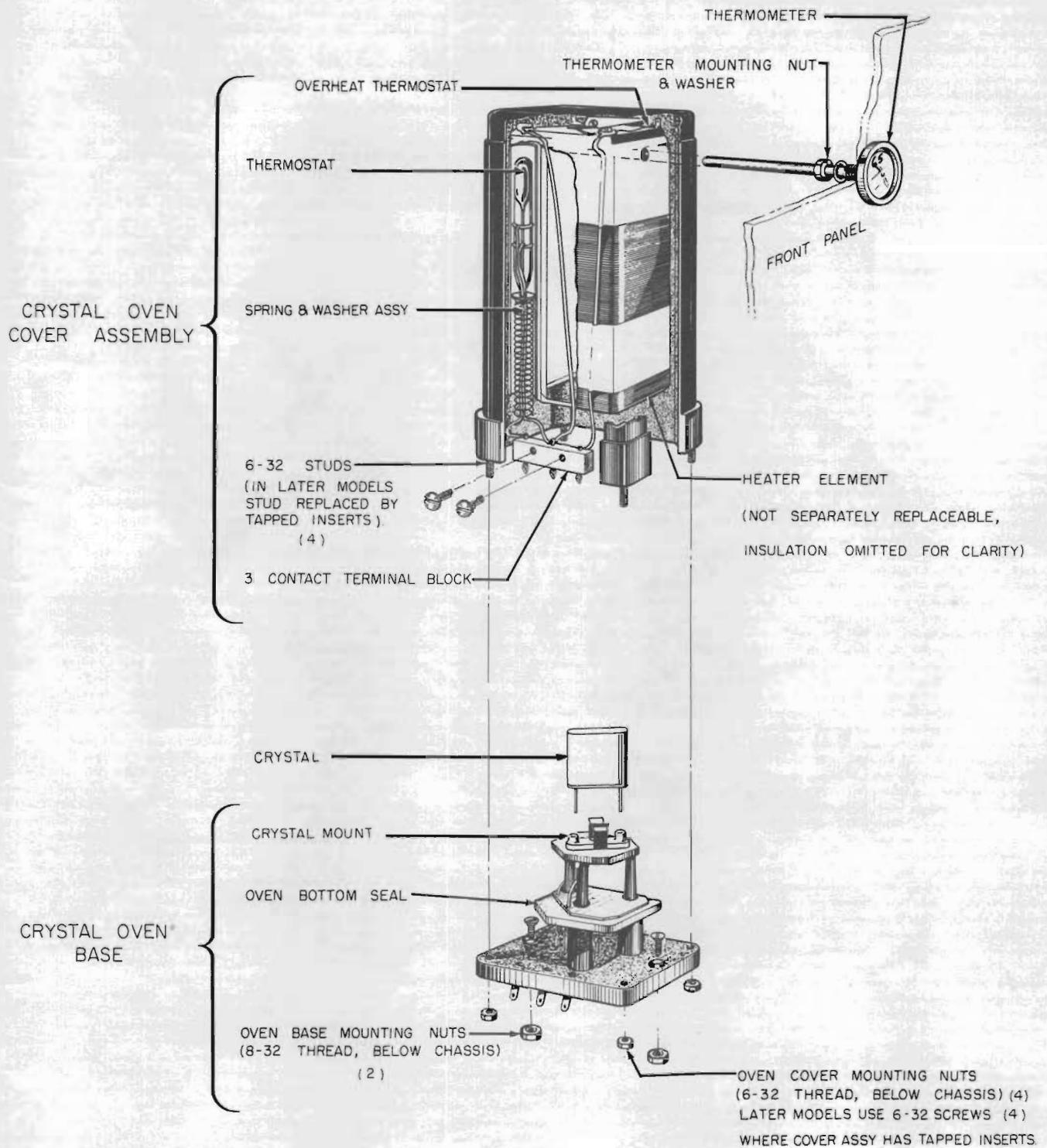

Fig. 4A. Exploded View of Crystal Oven

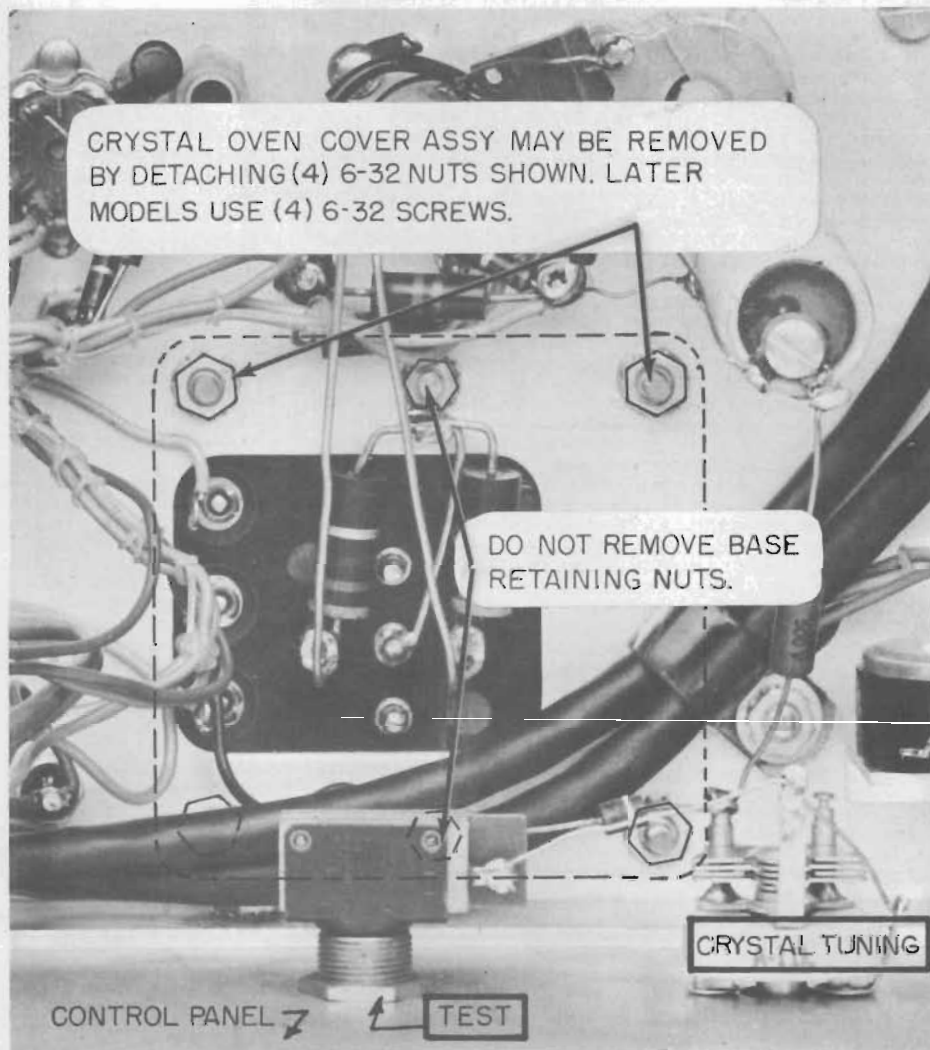

Fig. 4B. Location of Crystal Oven Mounting Screws

## Remote Meters --

Any or all of the front panel meter indications may be obtained remotely by connecting external meters to the instrument in place of the dummy meter resistors supplied with the Model 335E.

These remote meters are available from Hewlett-Packard. The meter movements and faces are identical with those on the control panel. Meters are furnished wired with correct series resistor and BNC connector. Two BNC cable connectors are furnished for making up the cable to connect the meter to the instrument.

The following designations should be used when ordering remote meters:

External AURAL CARRIER DEVIATION meter, Stock #335E-95A  
External PERCENT MODULATION meter, Stock #335E-95B  
External VISUAL CARRIER DEVIATION meter, Stock #335E-95C

### To install remote meter:

1. Make up cable with proper length of RG-55/U cable with UG-88/U connectors at either end.
2. Remove the appropriate dummy meter resistor.
3. Connect the cable to the external meter jack and external meter.
4. It is usually unnecessary to recalibrate the instrument. However any error introduced by installing the remote meter may be reduced by re-calibrating as follows:
  - a. When installing a remote VISUAL CARRIER DEVIATION meter, re-set adjustments A and B as indicated in the Visual Counter Section of the Circuit Adjustment and Maintenance Procedure.
  - b. When installing a remote AURAL CARRIER DEVIATION meter or PERCENT MODULATION meter, re-set adjustments C and D as indicated in the Aural Counter Section of the Circuit Adjustment and Maintenance Procedure.

The remote meters will give the same indications as the front panel meters in all positions of the FUNCTION SELECTOR switch except the PERCENT MODULATION meter in TUNE 1 position. In this position the remote PERCENT MODULATION meter will not indicate.

If desired, the faces of the remote meters may be illuminated by connecting 6.3 volts, AC or DC, to the designated terminals on the remote meters. The same procedure as that given for the meters mounted on the control panel should be used for replacing burned-out bulbs.

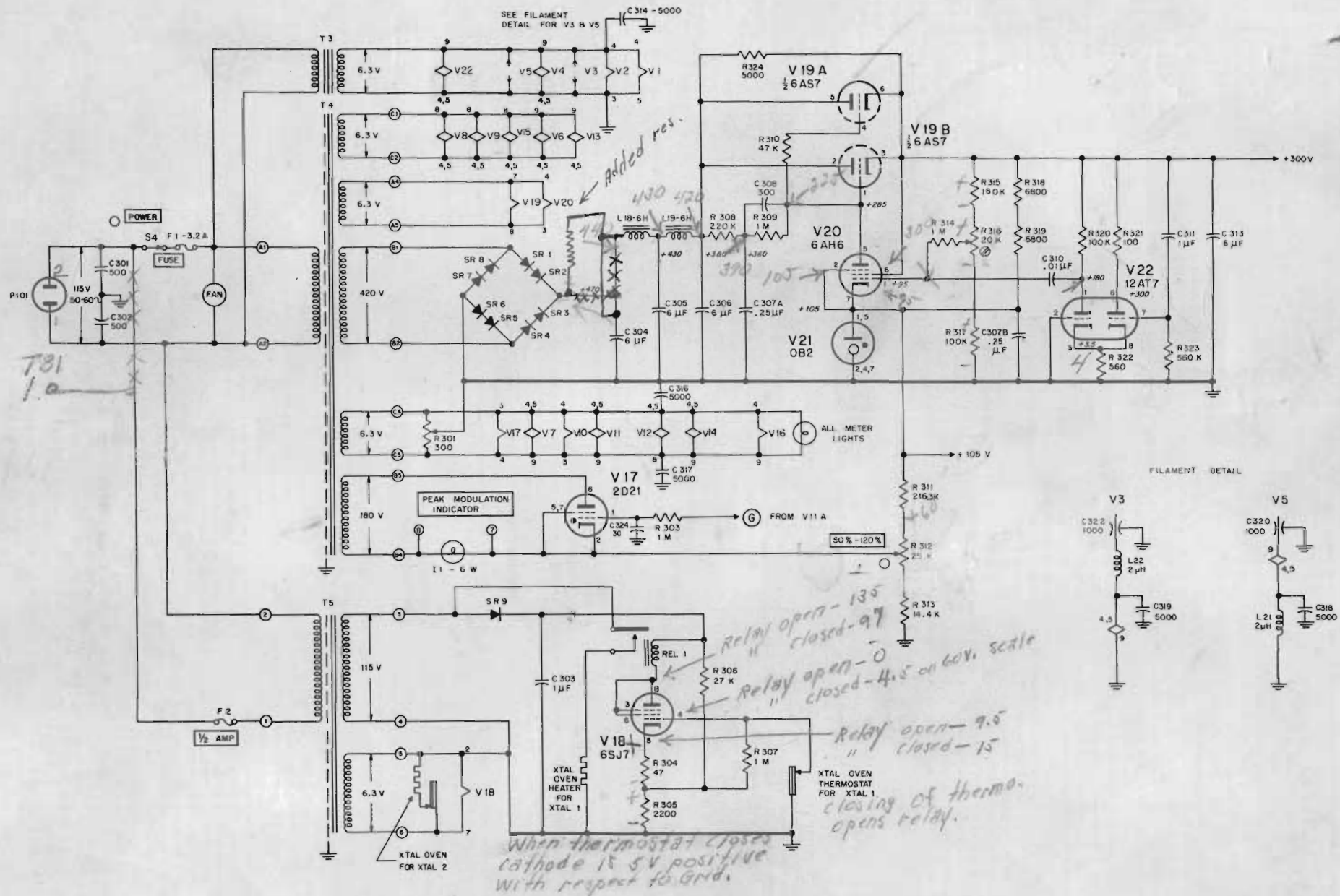

**SCHEMATIC DIAGRAM OF MODEL 335E**  
**TELEVISION MONITOR**  
**(POWER SUPPLY SECTION)**  
**SERIAL 1 & ABOVE**



26.201250  
 53.402500  
 114.825000

- S2 A-H
- ① CARRIER LEVEL
- ② 1
- ③ USE
- ④ 2
- ⑤ CALIBRATE

NOTES:  
 CONDITIONS OF DC VOLTAGE MEASUREMENT  
 1. LINE VOLTAGE AT 115 VOLTS, 50/60~  
 2. NO RF INPUT  
 3. DUMMY METER LOADS CONNECTED  
 4. MODULATION POLARITY SWITCH AT + POSITION  
 5. PEAK MODULATION INDICATOR (50%-100%) CONTROL AT 100%  
 6. VOLTAGES MEASURED BETWEEN INDICATED POINTS AND CHASSIS WITH VOLTMETER OF 122 MEGOHMS INPUT RESISTANCE  
 7. (+250) INDICATES VOLTAGES MEASURED IN USE POSITION  
 8. +250 INDICATES VOLTAGES MEASURED IN CALIBRATE POSITION  
 ALL CAPACITANCE IN  $\mu\text{F}$  RESISTANCE IN OHMS UNLESS OTHERWISE NOTED  
 K = 1000 OHMS M = 1 MEGOHM  $\text{---}$  CHASSIS  $\text{---}$  CATHODE  
 ○ PANEL CONTROL  
 ⊙ SCREWDRIVER ADJ.  
 \* ADJUSTED AT FACTORY FOR OPTIMUM PERFORMANCE. AVERAGE VALUE SHOWN

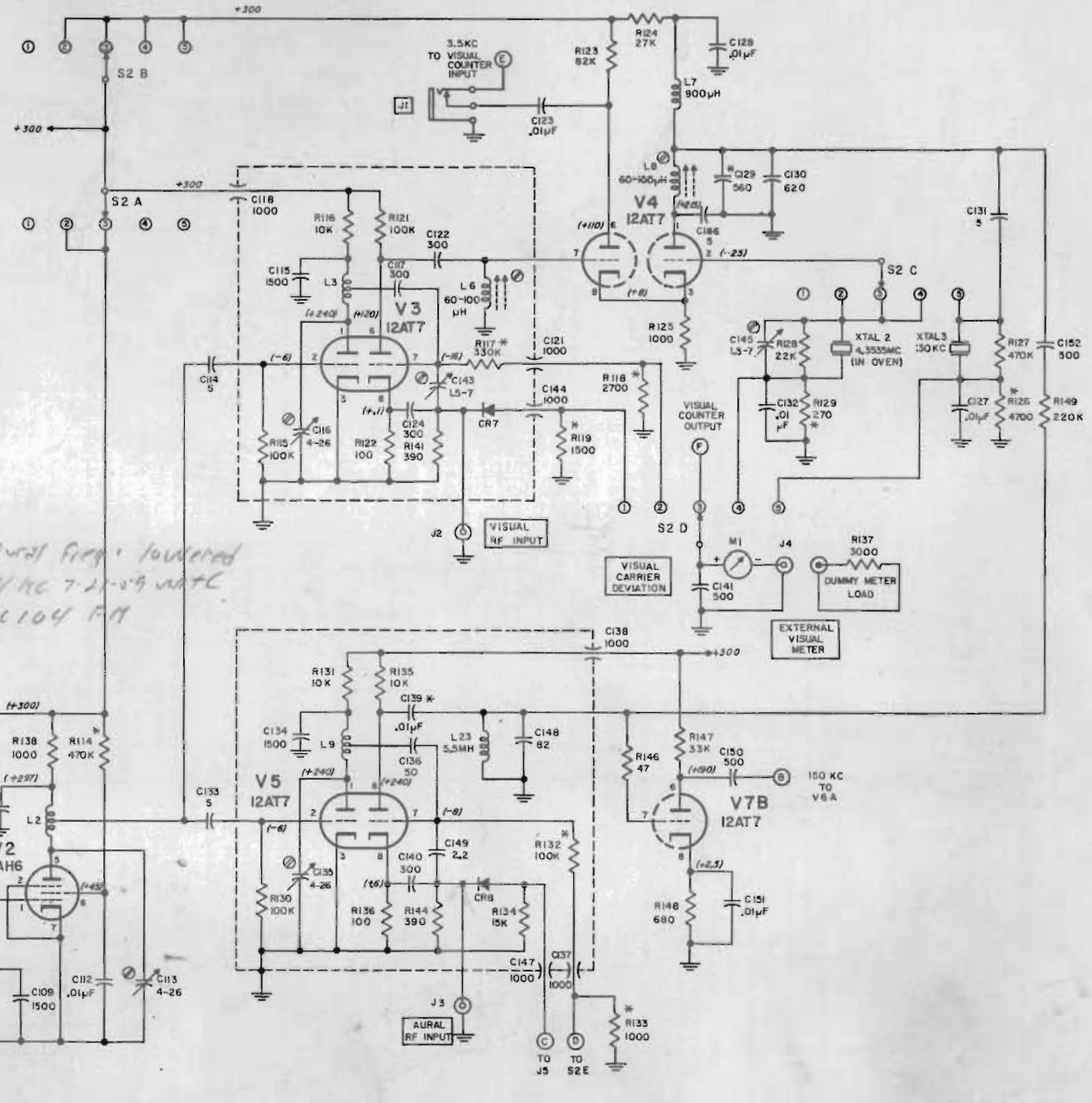

*Aural freq. indication raised 4KC*  
*Aural freq. lowered 6-19-56, fr. with C104*  
*Aural freq. ind. lowered 4KC 14KC 7-21-59 with C104 FM*  
*11-18-56 with C104 F.M.*

*NEW XTAL OCT. 1975*

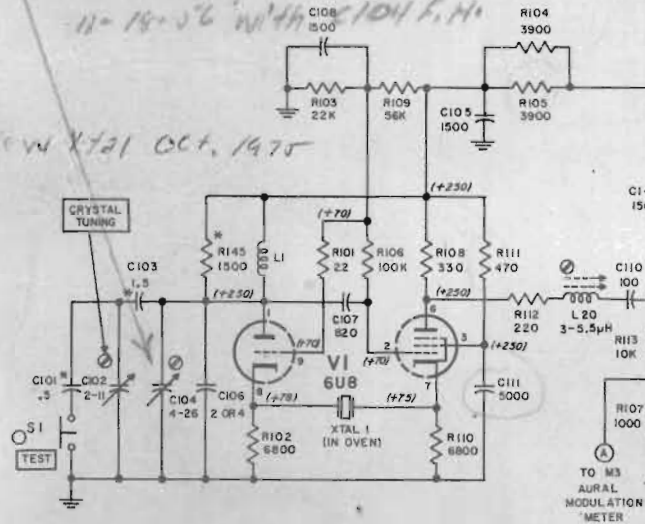

**SCHEMATIC DIAGRAM OF MODEL 335E**  
 TELEVISION MONITOR  
 (RF SECTION)  
 SERIAL 1 & ABOVE

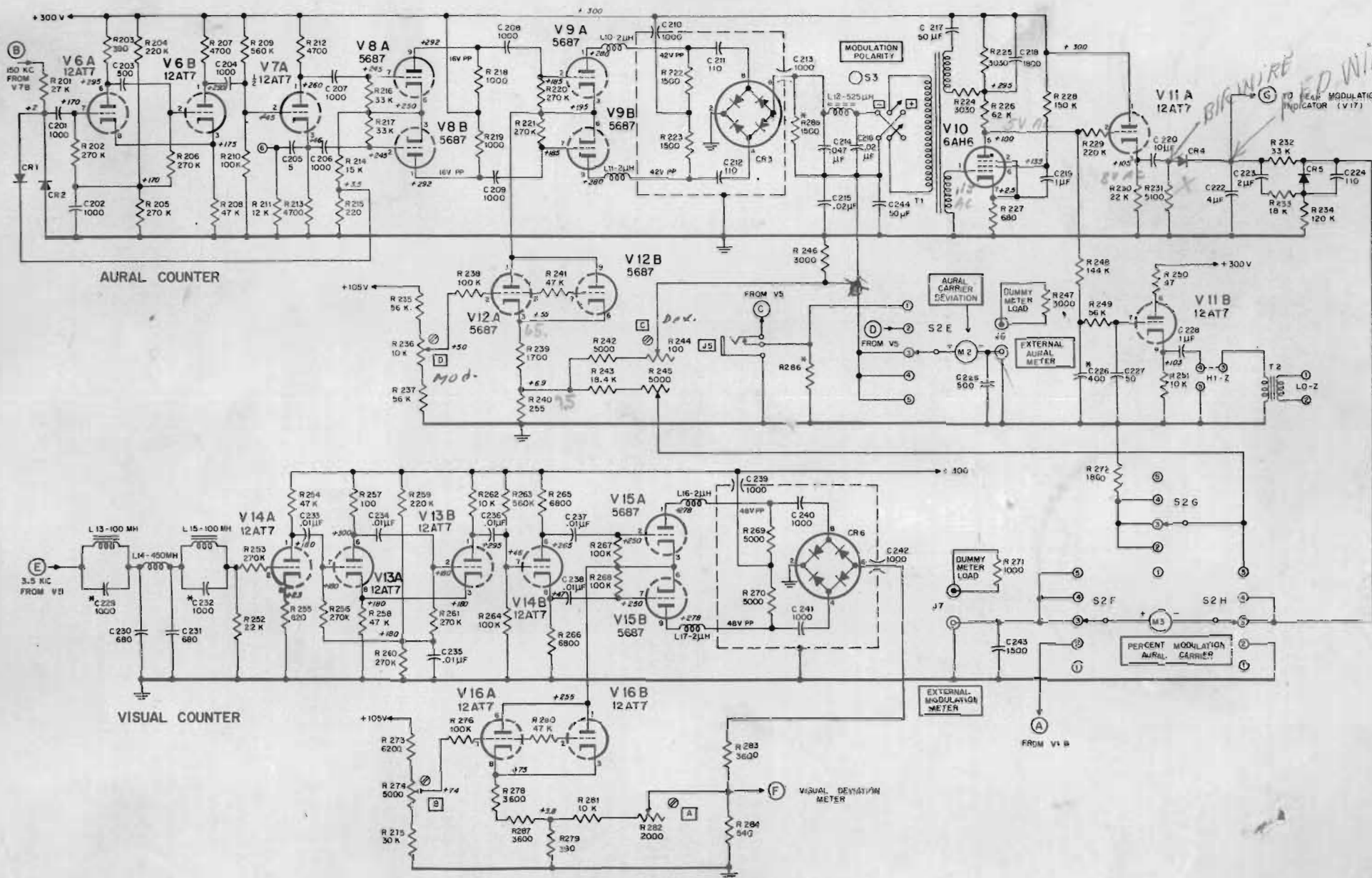

**SCHEMATIC DIAGRAM OF MODEL 335E  
TELEVISION MONITOR  
(COUNTER SECTION)  
SERIAL I & ABOVE**

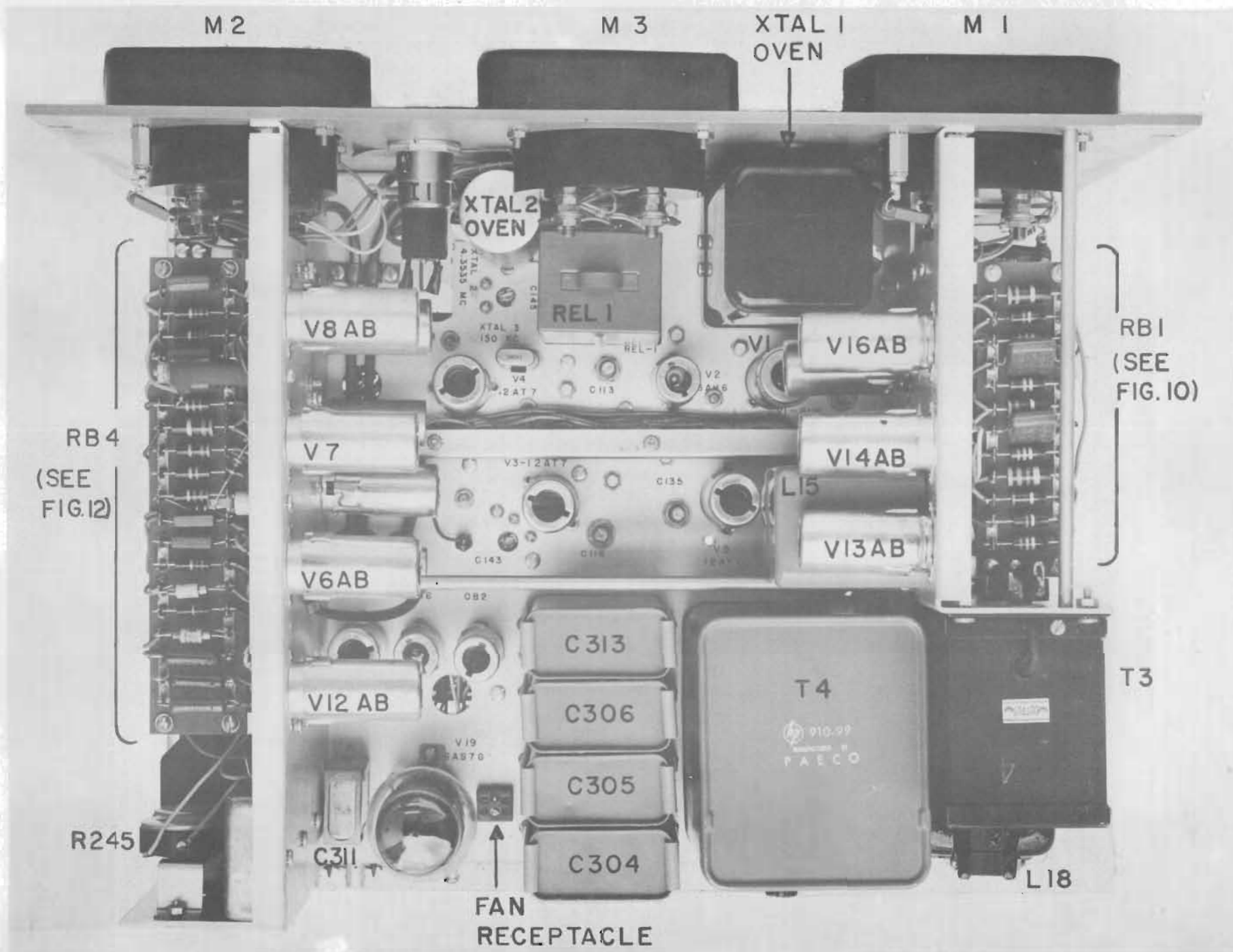

Fig. 5. Model 335E Top View with Cover Removed

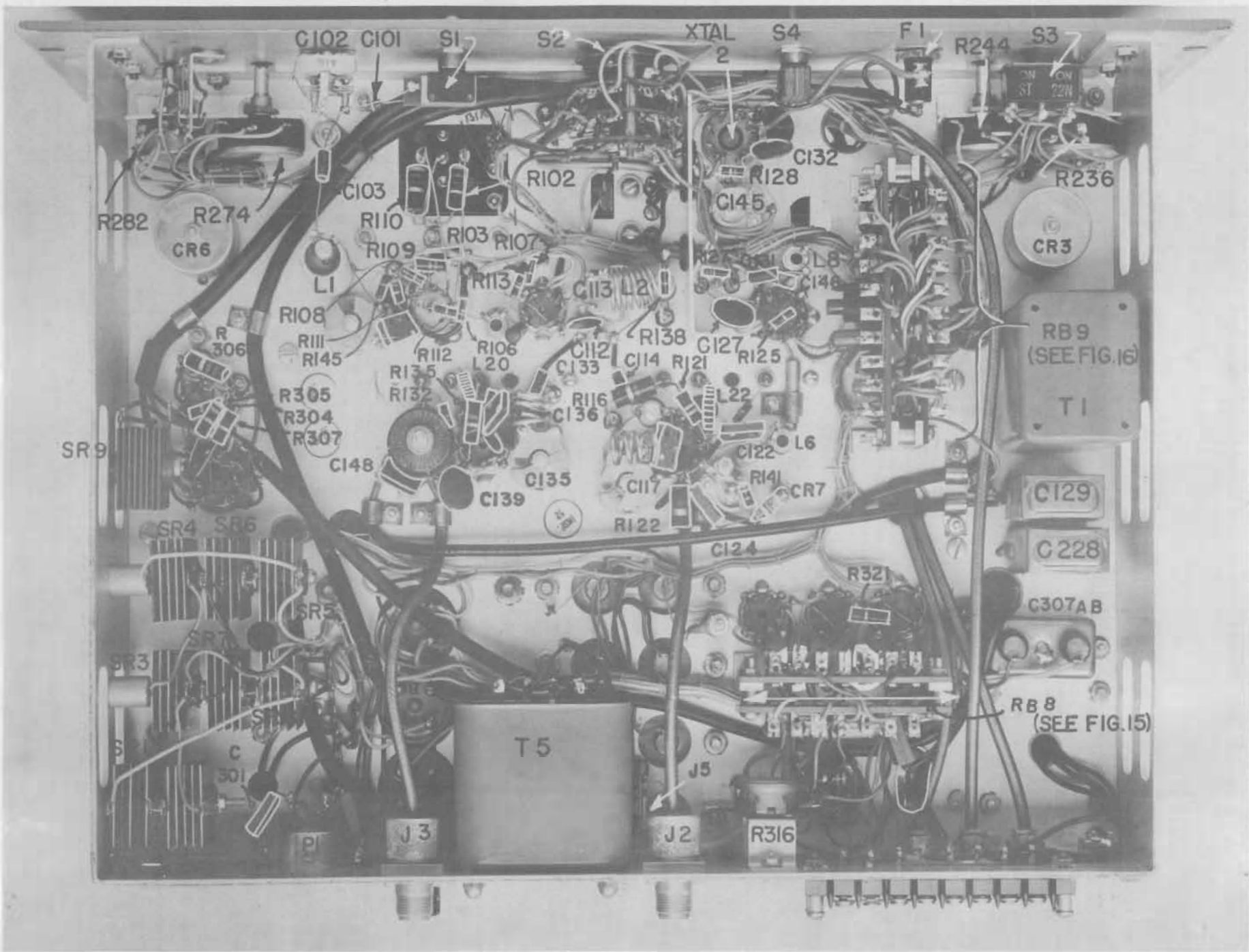

Fig. 6. Model 335E Bottom View with Cover Removed

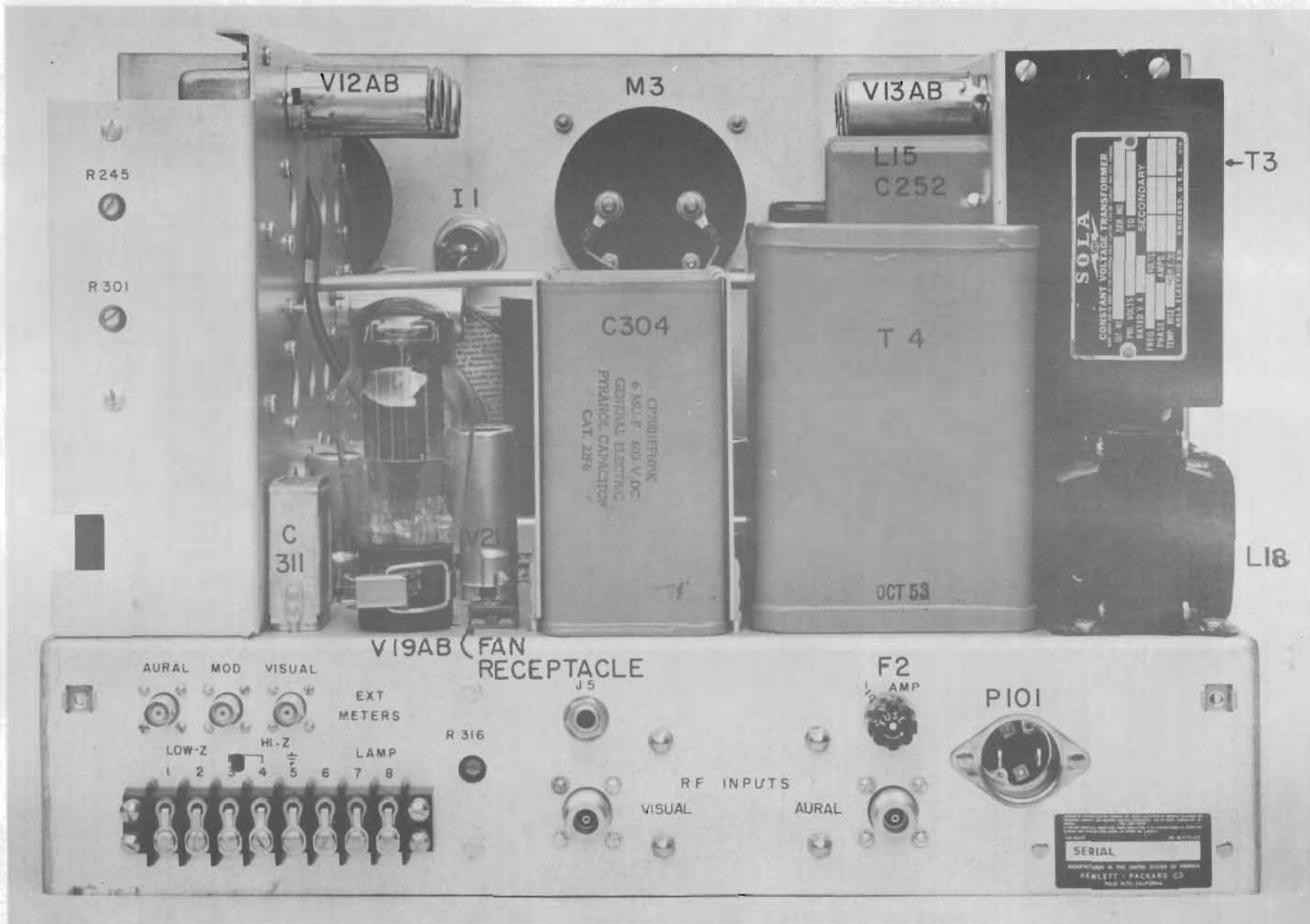

Fig. 7. Model 335E Rear View with Cover Removed

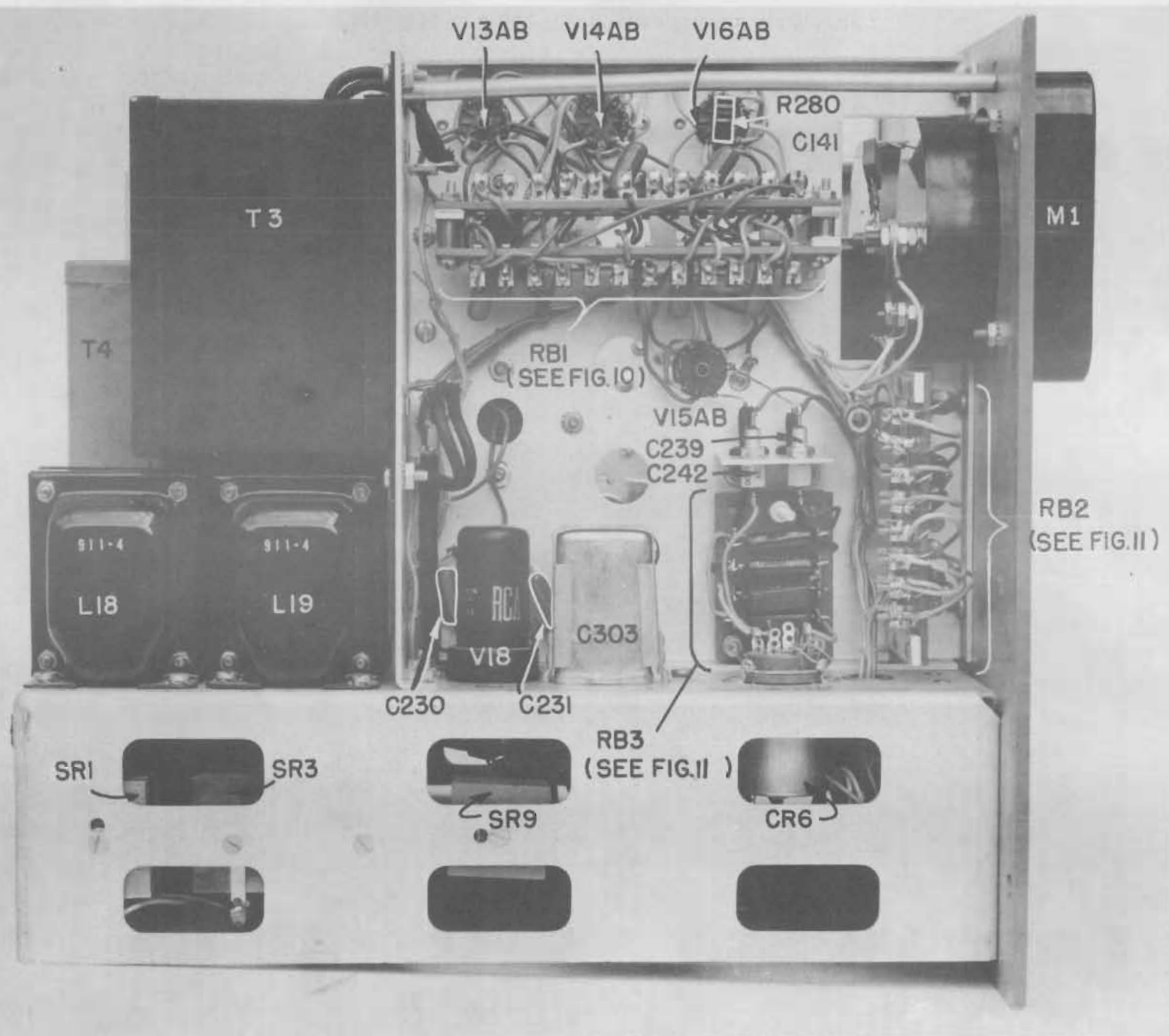

Fig. 8. Model 335E Left Side View with Cover Removed

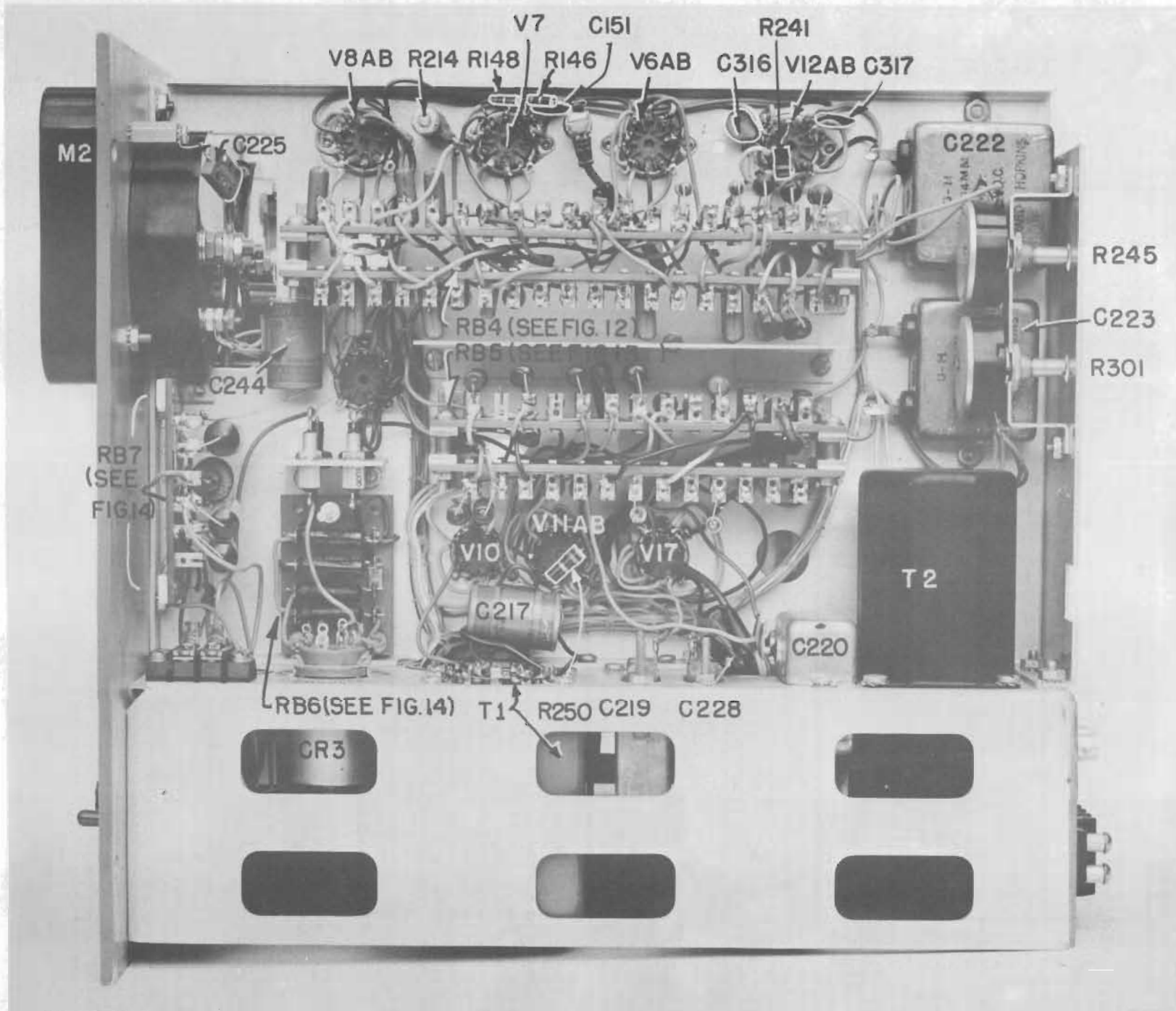

Fig. 9. Model 335E Right Side View with Cover Removed

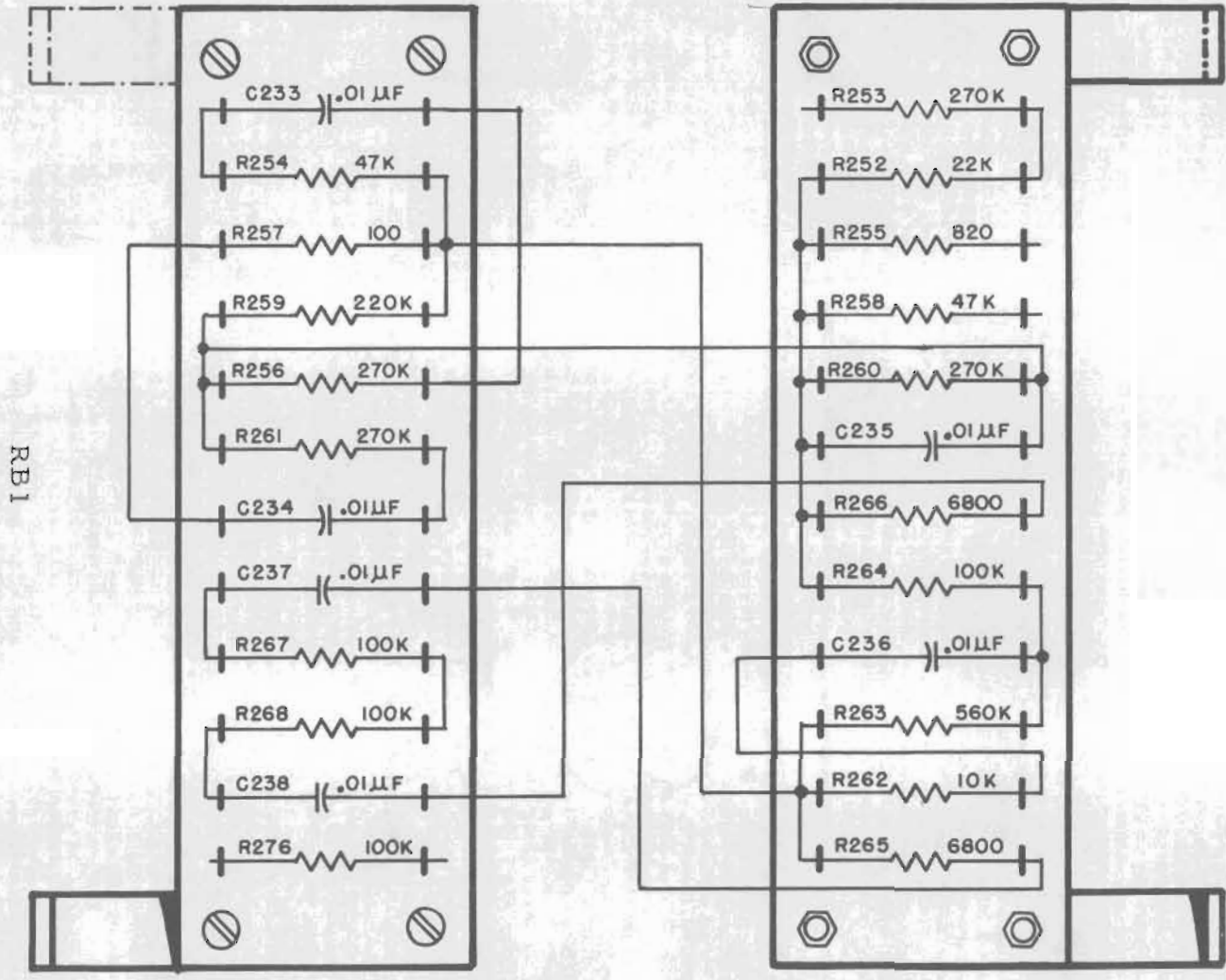

Fig. 10. Model 335E Resistor Board Details



NOTE: ALL RESISTORS  
ARE ON OPP SIDE  
OF BOARD EXCEPT  
R275.

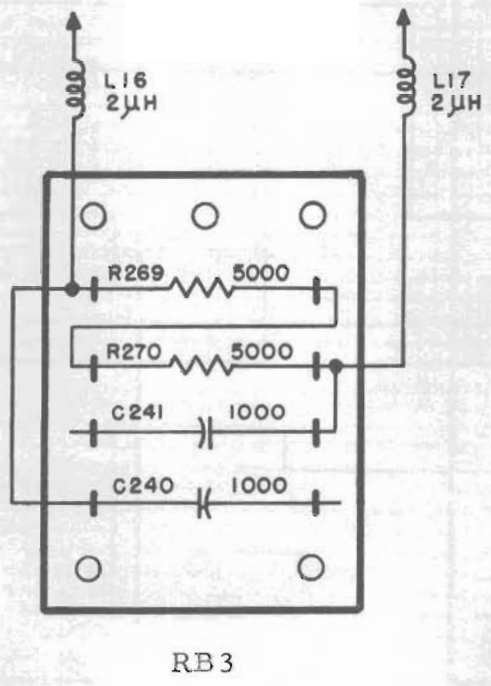
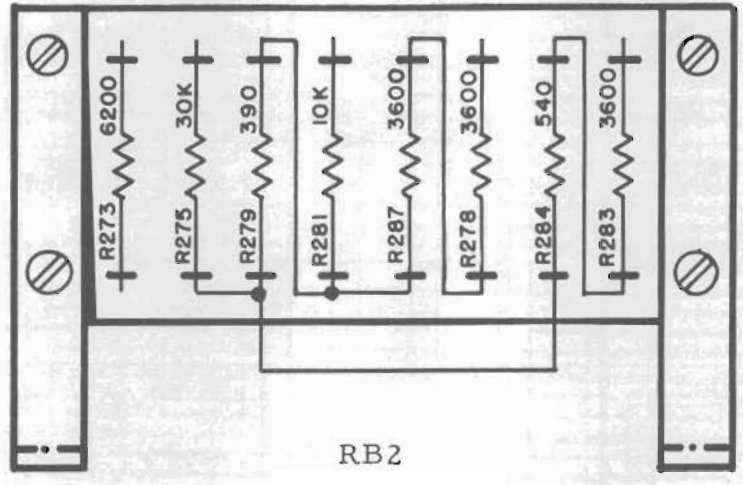

Fig. 11. Model 335E Resistor Board Detail

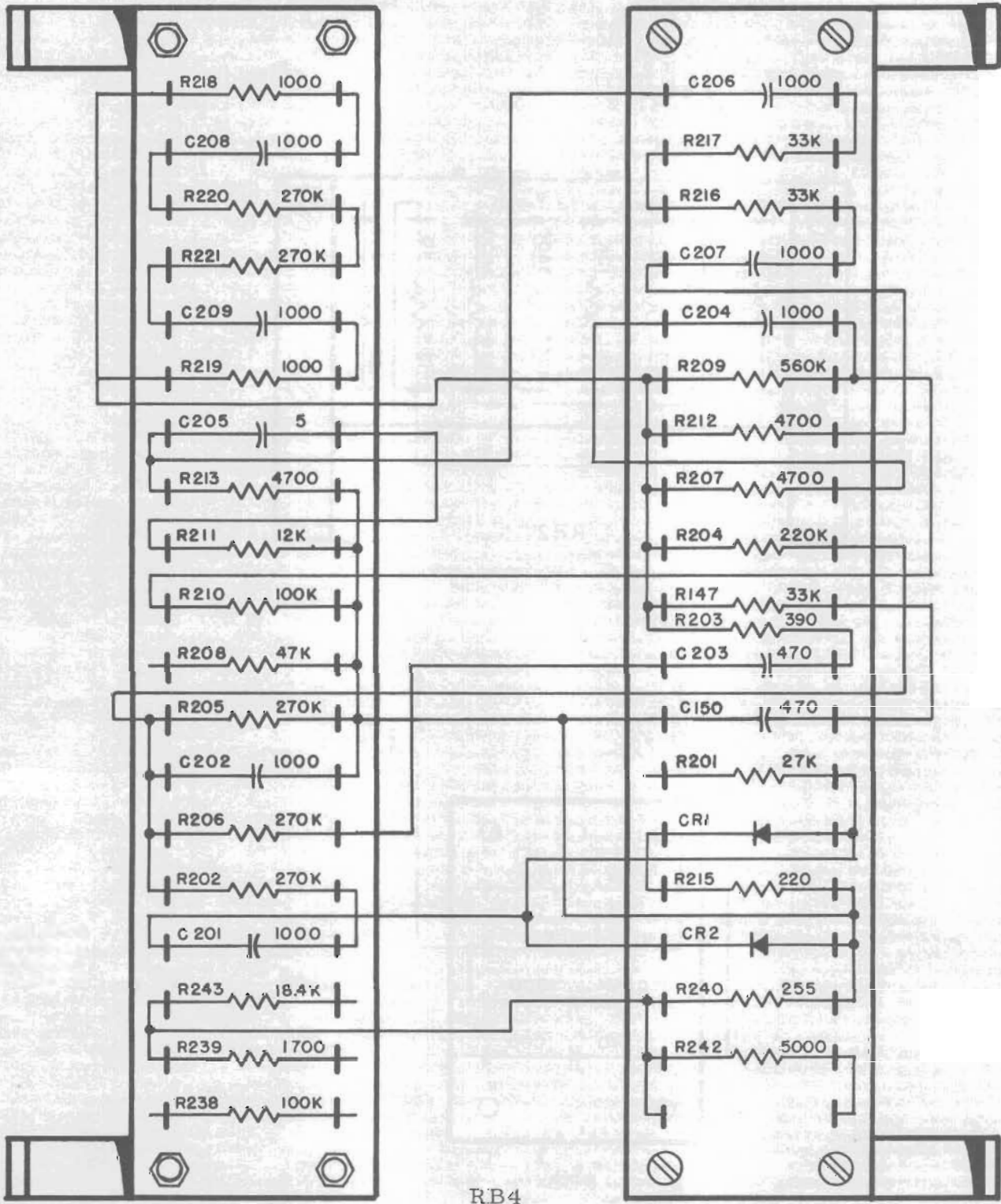

Fig. 12. Model 335E Resistor Board Detail

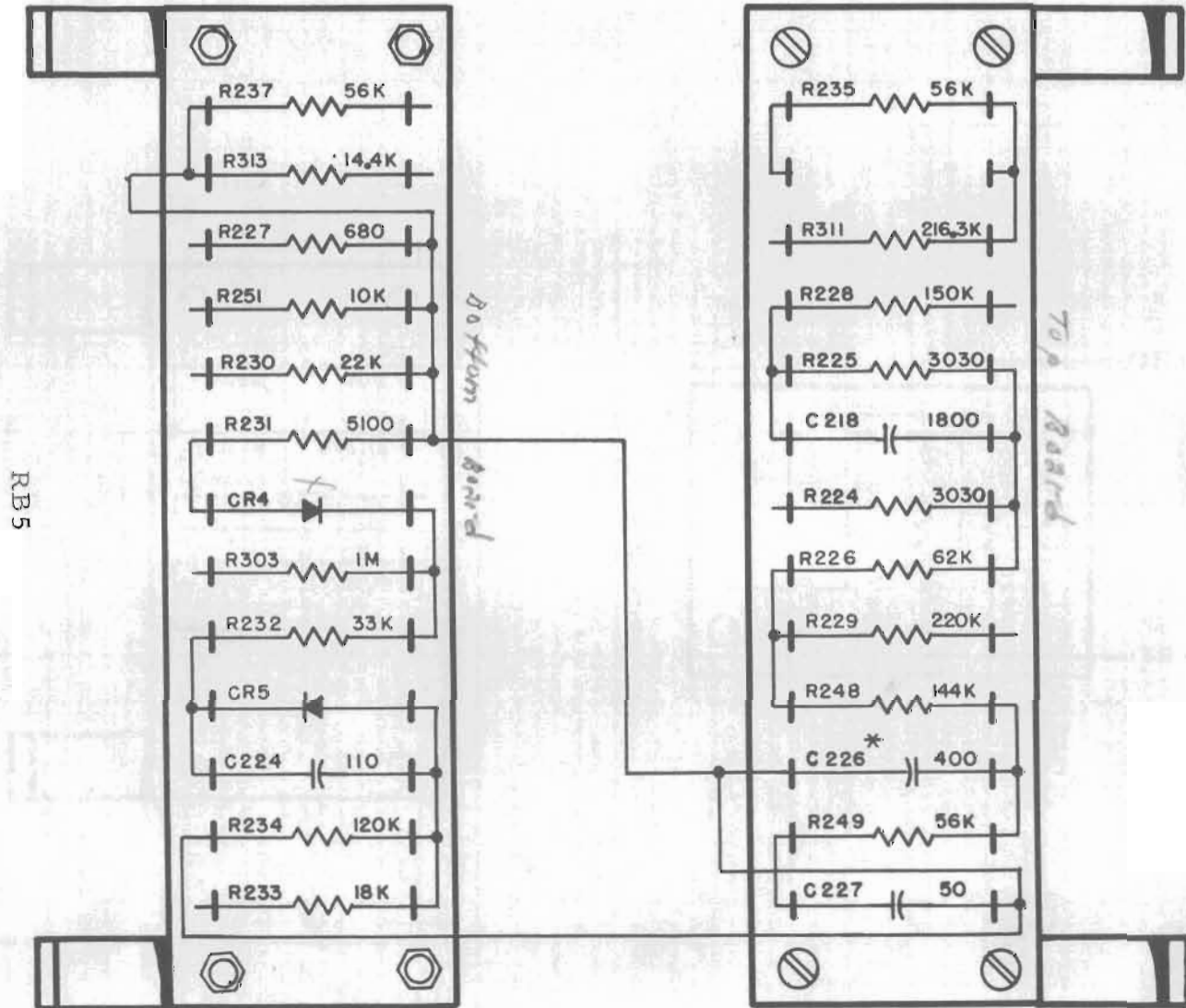

Fig. 13. Model 335E Resistor Board Detail

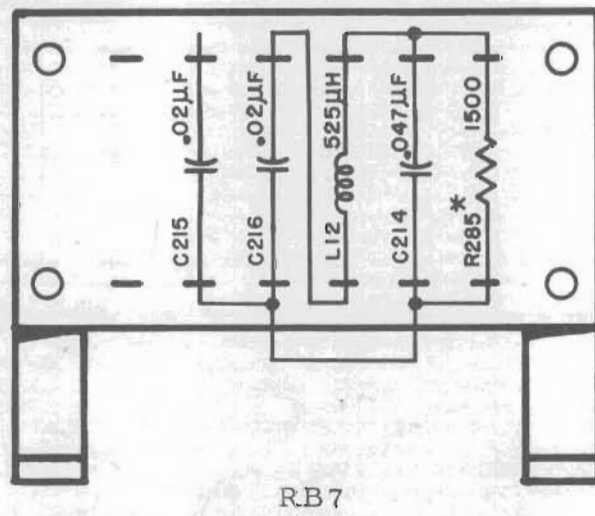
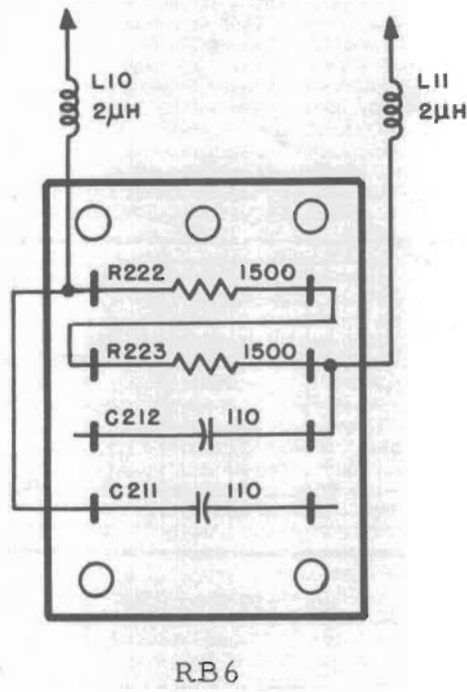
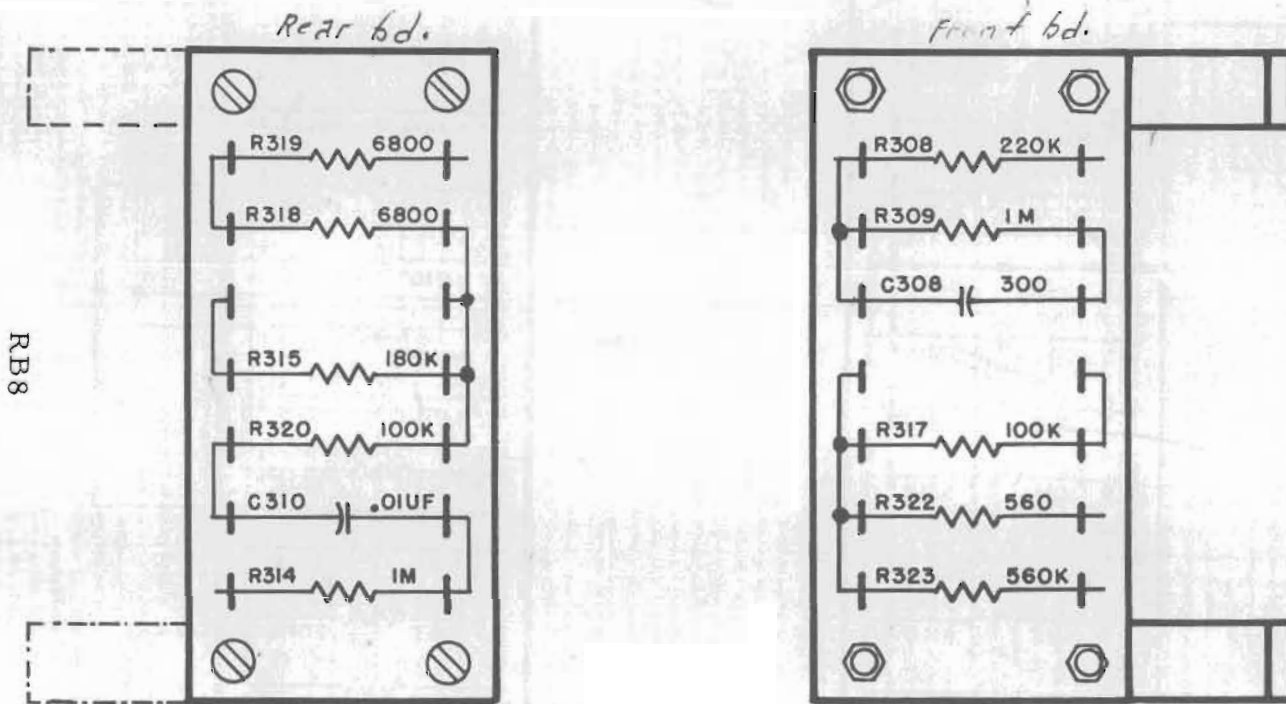

Fig. 14. Model 335E Resistor Board Detail.

Fig. 15. Model 335E Resistor Board Detail



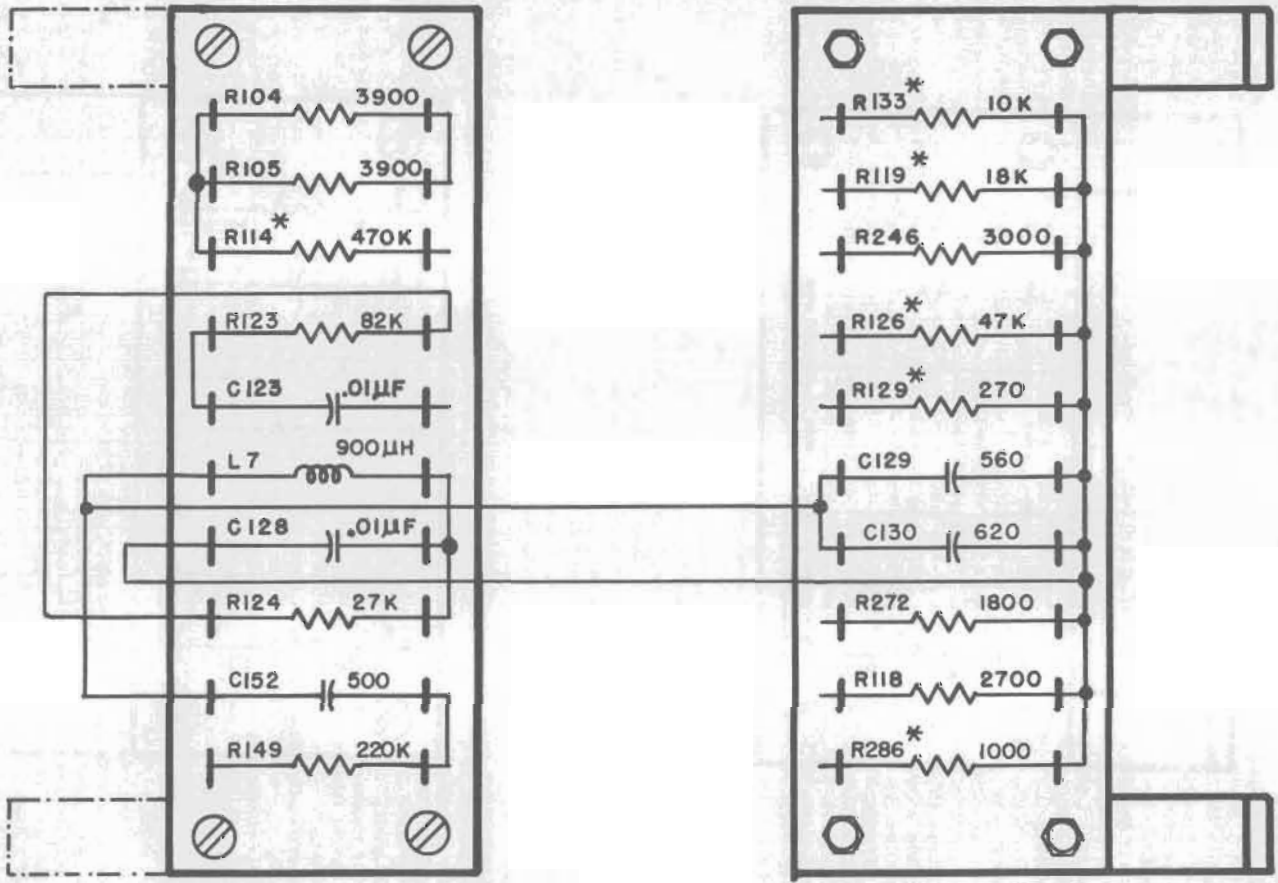

Fig. 16. Model 335E Resistor Board Detail

TABLE OF REPLACEABLE PARTS

Circuit Ref.	Description	-hp- Stock No.	Mfr. * & Mfrs. Designation
C101	Capacitor: fixed, titanium dioxide, .5 $\mu$ f, $\pm$ 5%, 500 vdcw	15-74	DD
C102	Capacitor: variable, air 2-11 $\mu$ f	12-21	AA #A-11L
C103	Capacitor: fixed, titanium dioxide dielectric, 1.5 $\mu$ f, $\pm$ 20%, 500 vdcw Electrical value adjusted at factory	15-38	DD GA-3
C104	Capacitor: variable, air, 4-26 $\mu$ f	12-10	AA #O-25L
C105	Capacitor: fixed, ceramic, 1500 $\mu$ f, $\pm$ 20%, 500 vdcw	15-70	L Style 326
C106	Capacitor: fixed, ceramic, 2 $\mu$ f, -1400 parts/million/degree C temp. coeff., 600 vdcw (25 - 28 Mc crystal frequency)	--	L Style 315
C106	Capacitor: fixed, ceramic, 4 $\mu$ f, -1400 parts/million/degree C temp. coeff, 600 vdcw (18 - 25 Mc crystal frequency)	--	L Style 315
C107	Capacitor: fixed, mica, 820 $\mu$ f, $\pm$ 10%, 500 vdcw 82.0	14-28	V
C108	Capacitor: fixed, ceramic, 1500 $\mu$ f, $\pm$ 20%, 500 vdcw	15-70	L Style 326
C109	Capacitor: fixed, ceramic, 1500 $\mu$ f, $\pm$ 20%, 500 vdcw	15-70	L Style 326
C110	Capacitor: fixed, ceramic, 100 $\mu$ f, $\pm$ 2%, 500 vdcw	15-22	A Type SI-19
C111	Capacitor: fixed, ceramic, 5000 $\mu$ f, 500 vdcw	15-47	A, HI-Q Div. Type BPD.005
C112	Capacitor: fixed, ceramic, .01 $\mu$ f, +100%, -0%, 500 vdcw	15-43	A, HI-Q Div. Type BPD.01
C113	Capacitor: variable, air, 4-26 $\mu$ f	12-10	AA #O-25L
C114	Capacitor: fixed, ceramic, 5 $\mu$ f, $\pm$ .5 $\mu$ f, NPO Temp. Coeff. 500 vdcw	15-29	A, HI-Q Div. CI-1
C115	Capacitor: fixed, ceramic, 1500 $\mu$ f, $\pm$ 20%, 500 vdcw	15-70	L Style 326

\*See "List of Manufacturers Code Letters For Replaceable Parts Table."

335E 1/22/54 Serial I and above

TABLE OF REPLACEABLE PARTS

Circuit Ref.	Description	-hp- Stock No.	Mfr. * & Mfrs. Designation
C116	Capacitor: fixed, air, 4-26 $\mu\text{mf}$	12-10	AA #O-25L
C117	Capacitor: fixed, mica, 300 $\mu\text{mf}$ , $\pm 10\%$ , 500 vdcw	14-300	V Type OXM
C118	Capacitor: fixed, ceramic, 1000 $\mu\text{mf}$ , $\pm 20\%$ , 500 vdcw	15-68	L Style 327
C119	Capacitor: fixed, mica, 500 $\mu\text{mf}$ , $\pm 10\%$ , 500 vdcw	14-500	V Type OXM
C120	Capacitor: fixed, mica, 150 $\mu\text{mf}$ , $\pm 10\%$ , 500 vdcw	14-150	V Type OXM
C121	Capacitor: fixed, ceramic, 1000 $\mu\text{mf}$ , $\pm 20\%$ , 500 vdcw	15-68	L Style 327
C122	Capacitor: fixed, mica, 300 $\mu\text{mf}$ , $\pm 10\%$ , 500 vdcw	14-300	V Type OXM
C123	Capacitor: fixed, mica, 100 $\mu\text{mf}$ , $\pm 10\%$ , 500 vdcw	14-100	Z K-1310
C124	Capacitor: fixed, mica, 300 $\mu\text{mf}$ , $\pm 10\%$ , 500 vdcw	14-300	V Type OXM
C125, C126	These circuit references not assigned		
C127	Capacitor: fixed, ceramic, .01 $\mu\text{f}$ , +100%, -0%, 500 vdcw	15-43	A, HI-Q Div. Type BPD. 01
C128	Capacitor: fixed, mica, .01 $\mu\text{f}$ , $\pm 10\%$ , 300 vdcw	14-23	V Type W
C129	Capacitor: fixed, silver mica, 560 $\mu\text{mf}$ , $\pm 5\%$ , 500 vdcw Electrical value adjusted at factory	15-11	A Type 1479
C130	Capacitor: fixed, silver mica, 620 $\mu\text{mf}$ , $\pm 5\%$ , 500 vdcw	15-12	A Type 1479
C131	Capacitor: fixed, ceramic, 5 $\mu\text{mf}$ , $\pm .5 \mu\text{mf}$ , NPO Temp. Coeff. 500 vdcw	15-29	A, HI-Q Div. CI-1
C132	Capacitor: fixed, ceramic, .01 $\mu\text{f}$ , +100%, -0%, 500 vdcw	15-43	A, HI-Q Div. Type BPD. 01
C133	Capacitor: fixed, ceramic, 5 $\mu\text{mf}$ , $\pm .5 \mu\text{mf}$ , NPO Temp. Coeff. 500 vdcw	15-29	A, HI-Q Div. CI-1
C134	Capacitor: fixed, ceramic 1500 $\mu\text{mf}$ , $\pm 20\%$ , 500 vdcw	15-70	L Style 326

\*See "List of Manufacturers Code Letters For Replaceable Parts Table."



TABLE OF REPLACEABLE PARTS

Circuit Ref.	Description	-hp- Stock No.	Mfr. * & Mfrs. Designation
C135	Capacitor: fixed, air, 4-26 $\mu\text{f}$	12-10	AA #O-25L
C136	Capacitor: fixed, mica, 50 $\mu\text{f}$ , $\pm 10\%$ , 500 vdcw	14-50	V Type OXM
C137	Capacitor: fixed, ceramic, 1000 $\mu\text{f}$ , $\pm 20\%$ , 500 vdcw	15-68	L Style 327
C138	Capacitor: fixed, ceramic, 1000 $\mu\text{f}$ , $\pm 20\%$ , 500 vdcw	15-68	L Style 327
C139	Capacitor: fixed, ceramic, .01 $\mu\text{f}$ , +100%, -0%, 500 vdcw	15-43	A, HI-Q Div Type BPD.01
C140	Capacitor: fixed, mica, 300 $\mu\text{f}$ , $\pm 10\%$ , 500 vdcw	14-300	V Type OXM
C141	Capacitor: fixed, mica, 500 $\mu\text{f}$ , $\pm 10\%$ , 500 vdcw	14-500	V Type OXM
C142	Capacitor: fixed, ceramic, 1500 $\mu\text{f}$ , $\pm 20\%$ , 500 vdcw	15-70	L Style 326
C143	Capacitor: variable, air, 1.5-7 $\mu\text{f}$	13-7	L TS2A NPO
C144	Capacitor: fixed, ceramic, 1000 $\mu\text{f}$ , $\pm 20\%$ , 500 vdcw	15-68	L Style 327
C145	Capacitor: variable, air, 1.5-7 $\mu\text{f}$	13-7	L TS2A NPO
C146	Capacitor: fixed, ceramic, 5 $\mu\text{f}$ , $\pm .5\%$ , NPO Temp. Coeff. 500 vdcw	15-29	A, HI-Q Div. CI-1
C147	Capacitor: fixed, ceramic, 1000 $\mu\text{f}$ , $\pm 20\%$ , 500 vdcw	15-68	L Style 327
C148	Capacitor: fixed, mica, 82 $\mu\text{f}$ , $\pm 10\%$ , 500 vdcw	14-19	V Type OXM
C149	Capacitor: fixed, titanium dioxide, 2.2 $\mu\text{f}$ , $\pm 10\%$ , Temp. Coeff. +2% of 20 C value over temp. range of -55 C to 85 C, 500 vdcw	15-52	DD GA-4
C150	Capacitor: fixed, mica, 500 $\mu\text{f}$ , $\pm 10\%$ , 500 vdcw	14-500	V Type OXM
C151	Capacitor: fixed, ceramic, .01 $\mu\text{f}$ , +100%, -0%, 500 vdcw	15-43	A, HI-Q Div. Type BPD.01

\*See "List of Manufacturers Code Letters For Replaceable Parts Table."

335E 1/22/54 Serial 1 and above

TABLE OF REPLACEABLE PARTS

Circuit Ref.	Description	-hp- Stock No.	Mfr. * & Mfrs. Designation
C152	Capacitor: fixed, mica, 500 $\mu$ mf, $\pm 10\%$ , 500 vdcw	14-500	V Type OXM
C153-C200	These circuit references not assigned		
C201	Capacitor: fixed, mica, 1,000 $\mu$ mf, $\pm 10\%$ , 500 vdcw	14-11	V Type W
C202	Capacitor: fixed, mica, 1,000 $\mu$ mf, $\pm 10\%$ , 500 vdcw	14-11	V Type W
C203	Capacitor: fixed, mica, 1,000 $\mu$ mf, $\pm 10\%$ , 500 vdcw	14-11	V Type W
C204	Capacitor: fixed, mica, 1,000 $\mu$ mf, $\pm 10\%$ , 500 vdcw	14-11	V Type W
C205	Capacitor: fixed, mica, 5 $\mu$ mf, $\pm 20\%$ , 500 vdcw	14-5	V Type OXM
C206	Capacitor: fixed, mica, 1,000 $\mu$ mf, $\pm 10\%$ , 500 vdcw	14-11	V Type W
C207	Capacitor: fixed, mica, 1,000 $\mu$ mf, $\pm 10\%$ , 500 vdcw	14-11	V Type W
C208	Capacitor: fixed, mica, 1,000 $\mu$ mf, $\pm 10\%$ , 500 vdcw	14-11	V Type W
C209	Capacitor: fixed, mica, 1,000 $\mu$ mf, $\pm 10\%$ , 500 vdcw	14-11	V Type W
C210	Capacitor: fixed, ceramic, 1,000 $\mu$ mf, $\pm 20\%$ , 500 vdcw	15-68	L Style 327
C211	Capacitor: fixed, ceramic, 110 $\mu$ mf, $\pm 2\%$ , 500 vdcw	15-22	A Type SI-19
C212	Capacitor: fixed, ceramic, 110 $\mu$ mf, $\pm 2\%$ , 500 vdcw	15-22	A Type SI-19
C213	Capacitor: fixed, ceramic, 1,000 $\mu$ mf, $\pm 20\%$ , 500 vdcw	15-68	L Style 327
C214	Capacitor: fixed, paper, .047 $\mu$ f, $\pm 10\%$ , 600 vdcw	16-15	CC
C215	Capacitor: fixed, paper, .02 $\mu$ mf, $\pm 10\%$ , 600 vdcw	16-12	A Type P688

\*See "List of Manufacturers Code Letters For Replaceable Parts Table."

335E 1/22/54 Serial 1 and above

TABLE OF REPLACEABLE PARTS

Circuit Ref.	Description	-hp- Stock No.	Mfr. * & Mfrs. Designation
C216	Capacitor: fixed, paper, .02 $\mu$ f, $\pm 10\%$ , 600 vdcw	16-12	A Type P688
C217	Capacitor: fixed, electrolytic, 50 $\mu$ f, +20%, -10%, 50 vdcw	18-50	X TC-39
C218	Capacitor: fixed, silver mica, 1800 $\mu$ f, $\pm 5\%$ , 500 vdcw	15-19	V Type PW
C219	Capacitor: fixed, paper, 1 $\mu$ f, $\pm 10\%$ , 600 vdcw	17-12	N #23F467
C220	Capacitor: fixed, electrolytic, 10 $\mu$ f, 300 vdcw	18-16	Z Type BTE
C221	This circuit reference not assigned		
C222	Capacitor: fixed, paper, 4 $\mu$ f, $\pm 10\%$ , 50 vdcw	17-43	P
C223	Capacitor: fixed, paper, 2 $\mu$ f, $\pm 10\%$ , 50 vdcw	17-42	P
C224	Capacitor: fixed, ceramic, 110 $\mu$ f, $\pm 2\%$ , 500 vdcw	15-22	A, HI-Q Div. Type SI-19
C225	Capacitor: fixed, mica, 500 $\mu$ f, $\pm 10\%$ , 500 vdcw	14-500	V Type OXM
C226	Capacitor: fixed, mica, 400 $\mu$ f, $\pm 10\%$ , 500 vdcw Electrical value adjusted at factory	14-400	V Type OXM
C227	Capacitor: fixed, mica, 50 $\mu$ f, $\pm 10\%$ , 500 vdcw	14-50	V Type OXM
C228	Capacitor: fixed, paper, 1 $\mu$ f, $\pm 10\%$ , 600 vdcw	17-12	N #23F467
C229	Capacitor: fixed, silver mica, 1000 $\mu$ f, $\pm 5\%$ , 500 vdcw Electrical value adjusted at factory	15-57	A CM30E102J
C230	Capacitor: fixed, mica, 680 $\mu$ f, $\pm 10\%$ , 500 vdcw	14-21	V Type W
C231	Capacitor: fixed, mica, 680 $\mu$ f, $\pm 10\%$ , 500 vdcw	14-21	V Type W
C232	Capacitor: fixed, silver mica, 1000 $\mu$ f, $\pm 5\%$ , 500 vdcw Electrical value adjusted at factory	15-57	A CM30E102J

\*See "List of Manufacturers Code Letters For Replaceable Parts Table."

332E 1/77/34 serial 1 and above

TABLE OF REPLACEABLE PARTS

Circuit Ref.	Description	-hp- Stock No.	Mfr. * & Mfrs. Designation
C233	Capacitor: fixed, mica, .01 $\mu$ f, $\pm 10\%$ , 300 vdcw	14-23	V Type W
C234	Capacitor: fixed, mica, .01 $\mu$ f, $\pm 10\%$ , 300 vdcw	14-23	V Type W
C235	Capacitor: fixed, mica, .01 $\mu$ f, $\pm 10\%$ , 300 vdcw	14-23	V Type W
C236	Capacitor: fixed, mica, .01 $\mu$ f, $\pm 10\%$ , 300 vdcw	14-23	V Type W
C237	Capacitor: fixed, mica, .01 $\mu$ f, $\pm 10\%$ , 500 vdcw	14-13	V Type W
C238	Capacitor: fixed, mica, .01 $\mu$ f, $\pm 10\%$ , 500 vdcw	14-13	V Type W
C239	Capacitor: fixed, ceramic, 1000 $\mu$ f, $\pm 20\%$ , 500 vdcw	15-68	L Style 327
C240	Capacitor: fixed, silver mica, 1000 $\mu$ f, $\pm 5\%$ , 500 vdcw	15-57	A
C241	Capacitor: fixed, silver mica, 1000 $\mu$ f, $\pm 5\%$ , 500 vdcw	15-57	A
C242	Capacitor: fixed, ceramic, 1000 $\mu$ f, $\pm 20\%$ , 500 vdcw	15-68	L Style 327
C243	Capacitor: fixed, ceramic, 1500 $\mu$ f, $\pm 20\%$ , 500 vdcw	15-70	L Style 326
C244	Capacitor: fixed, electrolytic, 50 $\mu$ f, +200%, -10%, 50 vdcw	18-50	X TC-39
C245-C300	These circuit references not assigned		
C301	Capacitor: fixed, mica, 500 $\mu$ f, $\pm 10\%$ , 500 vdcw	14-500	V Type OXM
C302	Capacitor: fixed, mica, 500 $\mu$ f, $\pm 10\%$ , 500 vdcw	14-500	V Type OXM
C303	Capacitor: fixed, paper, 1 $\mu$ f, $\pm 10\%$ , 600 vdcw	17-12	N #23F467
C304	Capacitor: fixed, paper, 6 $\mu$ f, $\pm 10\%$ , 600 vdcw	17-11	N 22F6

\*See "List of Manufacturers Code Letters For Replaceable Parts Table."

TABLE OF REPLACEABLE PARTS

Circuit Ref.	Description	-hp- Stock No.	Mfr. * & Mfrs. Designation
C305	Capacitor: fixed, paper, 6 $\mu$ f, $\pm 10\%$ , 600 vdcw	17-11	N 22F6
C306	Capacitor: fixed, paper, 6 $\mu$ f, $\pm 10\%$ , 600 vdcw	17-11	N 22F6
C307AB	Capacitor: fixed, paper, .25, .25 $\mu$ f, $\pm 20\%$ , 600 vdcw	17-14	N 22F427
C308	Capacitor: fixed, mica, 300 $\mu$ f, $\pm 10\%$ , 500 vdcw	14-300	V Type OXM
C309	This circuit reference not assigned		
C310	Capacitor: fixed, mica, .01 $\mu$ f, $\pm 10\%$ , 300 vdcw	14-23	V Type W
C311	Capacitor: fixed, paper, 1 $\mu$ f, $\pm 10\%$ , 600 vdcw	17-12	N #23F467
C312	This circuit reference not assigned		
C313	Capacitor: fixed, paper, 6 $\mu$ f, $\pm 10\%$ , 600 vdcw	17-11	N 22F6
C314	Capacitor: fixed, ceramic, 5000 $\mu$ f min., 500 vdcw	15-47	A, HI-Q Div. BPD.005
C315	Capacitor: fixed, ceramic, 5000 $\mu$ f min., 500 vdcw	15-47	A, HI-Q Div. BPD.005
C316	Capacitor: fixed, ceramic, 5000 $\mu$ f min., 500 vdcw	15-47	A, HI-Q Div. BPD.005
C317	Capacitor: fixed, ceramic, 5000 $\mu$ f min., 500 vdcw	15-47	A, HI-Q Div. BPD.005
C318	Capacitor: fixed, ceramic, 5000 $\mu$ f min., 500 vdcw	15-47	A, HI-Q Div. BPD.005
C319	Capacitor: fixed, ceramic, 5000 $\mu$ f min., 500 vdcw	15-47	A, HI-Q Div. BPD.005
C320	Capacitor: fixed, ceramic, 1000 $\mu$ f, $\pm 20\%$ , 500 vdcw	15-68	L Style 327
C321	Capacitor: fixed, ceramic, 1000 $\mu$ f, $\pm 20\%$ , 500 vdcw	15-68	L Style 327
C322	Capacitor: fixed, ceramic, 1000 $\mu$ f, $\pm 20\%$ , 500 vdcw	15-68	L Style 327

\*See "List of Manufacturers Code Letters For Replaceable Parts Table."

335E 1/22/54 Serial 1 and above

TABLE OF REPLACEABLE PARTS

Circuit Ref.	Description	-hp- Stock No.	Mfr. * & Mfrs. Designation
C323	Capacitor: fixed, ceramic, 1000 $\mu$ f, $\pm$ 20%, 500 vdcw	15-68	L Style 327
C324	Capacitor: fixed, mica, 30 $\mu$ f, $\pm$ 10%, 500 vdcw	14-30	V Type OXM

\*See "List of Manufacturers Code Letters For Replaceable Parts Table."

335E 1/22/54 Serial 1 and above

TABLE OF REPLACEABLE PARTS

Circuit Ref.	Description	-hp- Stock No.	Mfr. * & Mfrs. Designation
R101	Resistor: fixed, composition, 22 ohms, ±10%, 1/2 W	23-22	B EB 2201
R102	Resistor: fixed, composition, 6,800 ohms, ±10%, 2 W	25-6800	B HB 6821
R103	Resistor: fixed, composition, 22,000 ohms, ±10%, 1/2 W	23-22K	B EB 2231
R104	Resistor: fixed, composition, 3,900 ohms, ±10%, 1 W	24-3900	B GB 3921
R105	Resistor: fixed, composition, 3,900 ohms, ±10%, 1 W	24-3900	B GB 3921
R106	Resistor: fixed, composition, 100,000 ohms, ±10%, 1/2 W	23-100K	B EB 1041
R107	Resistor: fixed, composition, 1000 ohms, ±10%, 1/2 W	23-1000	B EB 1021
R108	Resistor: fixed, composition, 330 ohms, ±10%, 1/2 W	23-330	B EB 3311
R109	Resistor: fixed, composition, 56,000 ohms, ±10%, 1 W	24-56K	B GB 5631
R110	Resistor: fixed, composition, 6,800 ohms, ±10%, 2 W	25-6800	B HB 6821
R111	Resistor: fixed, composition, 470 ohms, ±10%, 1/2 W	23-470	B EB 4711
R112	Resistor: fixed, composition, 220 ohms, ±10%, 1/2 W	23-220	B EB 2231
R113	Resistor: fixed, composition, 10,000 ohms, ±10%, 1/2 W	23-10K	B EB 1031
R114	Resistor: fixed, composition, 470,000 ohms, ±10%, 1 W Electrical value adjusted at factory	24-470K	B GB 4741
R115	Resistor: fixed, composition, 100,000 ohms, ±10%, 1/2 W	23-100K	B EB 1041
R116	Resistor: fixed, composition, 10,000 ohms, ±10%, 2 W	25-10K	B HB 1031
R117	Resistor: fixed, composition, 330,000 ohms, ±10%, 1/2 W Electrical value adjusted at factory	23-330K	B EB 3341

\*See "List of Manufacturers Code Letters For Replaceable Parts Table."

335E 1/22/54 Serial 1 and above

TABLE OF REPLACEABLE PARTS

Circuit Ref.	Description	-hp- Stock No.	Mfr. * & Mfrs. Designation
R118	Resistor: fixed, composition, 2,700 ohms, $\pm 10\%$ , 1 W Electrical value adjusted at factory	24-2700	B GB 2721
R119	Resistor: fixed, composition, 1,500 ohms, $\pm 10\%$ , 1 W Electrical value adjusted at factory	24-1500	B GB 1521
R120	This circuit reference not assigned		
R121	Resistor: fixed, composition, 100,000 ohms, $\pm 10\%$ , 1 W	24-100K	B GB 1041
R122	Resistor: fixed, composition, 100 ohms, $\pm 10\%$ , 2 W	25-100	B HB 1011
R123	Resistor: fixed, composition, 82,000 ohms, $\pm 10\%$ , 1 W	24-82K	B GB 8231
R124	Resistor: fixed, composition, 27,000 ohms, $\pm 10\%$ , 2 W	25-27K	B HB 2731
R125	Resistor: fixed, composition, 1,000 ohms, $\pm 10\%$ , 1/2 W	23-1000	B EB 1021
R126	Resistor: fixed, composition, 47,000 ohms, $\pm 10\%$ , 1 W Electrical value adjusted at factory	24-47K	B GB 4731
R127	Resistor: fixed, composition, 470,000 ohms, $\pm 10\%$ , 1/2 W	23-470K	B EB 4741
R128	Resistor: fixed, composition, 22,000 ohms, $\pm 10\%$ , 1/2 W	23-22	B EB 2231
R129	Resistor: fixed, composition, 270 ohms, $\pm 10\%$ , 1 W Electrical value adjusted at factory	24-270	B GB 2711
R130	Resistor: fixed, composition, 100,000 ohms, $\pm 10\%$ , 1/2 W	23-100K	B EB 1041
R131	Resistor: fixed, composition, 10,000 ohms, $\pm 10\%$ , 2 W	25-10K	B HB 1031
R132	Resistor: fixed, composition, 100,000 ohms, $\pm 10\%$ , 1/2 W Electrical value adjusted at factory	23-100K	B EB 1041
R133	Resistor: fixed, composition, 10,000 ohms, $\pm 10\%$ , 1 W Electrical value adjusted at factory	24-10K	B GB 1031

\*See "List of Manufacturers Code Letters For Replaceable Parts Table."

335E 1/22/54 Serial 1 and above



TABLE OF REPLACEABLE PARTS

Circuit Ref.	Description	-hp- Stock No.	Mfr. * & Mfrs. Designation
R134	Resistor: fixed, composition, 15,000 ohms, $\pm 10\%$ , 1/2 W	23-15K	B GB 1531
R135	Resistor: fixed, composition, 10,000 ohms, $\pm 10\%$ , 2 W	24-10K	B HB 1031
R136	Resistor: fixed, composition, 100 ohms, $\pm 10\%$ , 2 W	25-100	B HB 1011
R137	Dummy Meter Load Assembly 3000 ohms	336C-53	HP
R138	Resistor: fixed, composition, 1,000 ohms, $\pm 10\%$ , 1/2 W	23-1000	B EB 1021
R139, R140	These circuit references not assigned		
R141	Resistor: fixed, composition 390 ohms, $\pm 10\%$ , 1/2 W	23-390	B EB 3911
R142, R143	These circuit references not assigned		
R144	Resistor: fixed, composition, 390 ohms, $\pm 10\%$ , 1/2 W	23-390	B EB 3911
R145	Resistor: fixed, composition, 1,500 ohms, $\pm 10\%$ , 1/2 W Electrical value adjusted at factory	23-1500	B EB 1521
R146	Resistor: fixed, composition, 47 ohms, $\pm 10\%$ , 1/2 W	23-47	B EB 4701
R147	Resistor: fixed, composition, 33,000 ohms, $\pm 10\%$ , 1 W	24-33K	B GB 3331
R148	Resistor: fixed, composition, 680 ohms, $\pm 10\%$ , 1/2 W	23-680	B EB 6811
R149	Resistor: fixed, composition, 220,000 ohms, $\pm 10\%$ , 1 W	24-220K	B EB 2241
R150 - R200	These circuit references not assigned		
R201	Resistor: fixed, composition, 27,000 ohms, $\pm 10\%$ , 1 W	24-27K	B GB 2731
R202	Resistor: fixed, composition, 270,000 ohms, $\pm 10\%$ , 1 W	24-270K	B GB 2741

\*See "List of Manufacturers Code Letters For Replaceable Parts Table."

335E 1/22/54 Serial 1 and above

TABLE OF REPLACEABLE PARTS

Circuit Ref.	Description	-hp- Stock No.	Mfr. * & Mfrs. Designation
R203	Resistor: fixed, composition, 390 ohms, $\pm 10\%$ , 1/2 W	23-390	B EB 3911
R204	Resistor: fixed, composition, 220,000 ohms, $\pm 10\%$ , 1 W	24-220K	B GB 2241
R205	Resistor: fixed, composition, 270,000 ohms, $\pm 10\%$ , 1 W	24-270K	B GB 2741
R206	Resistor: fixed, composition, 270,000 ohms, $\pm 10\%$ , 1 W	24-270K	B GB 2741
R207	Resistor: fixed, composition, 4,700 ohms, $\pm 10\%$ , 1 W	24-4700	B GB 4721
R208	Resistor: fixed, composition, 47,000 ohms, $\pm 10\%$ , 1 W	24-47K	B GB 4731
R209	Resistor: fixed, composition, 560,000 ohms, $\pm 10\%$ , 1 W	24-560K	B GB 5641
R210	Resistor: fixed, composition, 100,000 ohms, $\pm 10\%$ , 1 W	24-100K	B GB 1041
R211	Resistor: fixed, composition, 12,000 ohms, $\pm 10\%$ , 1 W	24-12K	B GB 1231
R212	Resistor: fixed, composition, 4,700 ohms, $\pm 10\%$ , 2 W	25-4700	B HB 4721
R213	Resistor: fixed, composition, 4,700 ohms, $\pm 10\%$ , 2 W	25-4700	B HB 4721
R214	Resistor: fixed, wirewound, 15,000 ohms, $\pm 10\%$ , 10 W	26-25	S Type 1-3/4E
R215	Resistor: fixed, composition, 220 ohms, $\pm 10\%$ , 1 W	24-220	B GB 2211
R216	Resistor: fixed, composition, 33,000 ohms, $\pm 10\%$ , 1 W	24-33K	B GB 3331
R217	Resistor: fixed, composition, 33,000 ohms, $\pm 10\%$ , 1 W	24-33K	B GB 3331
R218	Resistor: fixed, composition, 1,000 ohms, $\pm 10\%$ , 1 W	25-1000	B HB 1021
R219	Resistor: fixed, composition, 1,000 ohms, $\pm 10\%$ , 1 W	25-1000	B HB 1021

\*See "List of Manufacturers Code Letters For Replaceable Parts Table."

TABLE OF REPLACEABLE PARTS

Circuit Ref.	Description	-hp- Stock No.	Mfr. * & Mfrs. Designation
R220	Resistor: fixed, composition, 270,000 ohms, $\pm 10\%$ , 1 W	24-270K	B GB 2741
R221	Resistor: fixed, composition, 270,000 ohms, $\pm 10\%$ , 1 W	24-270K	B GB 2741
R222	Resistor: fixed, wirewound, 1,500 ohms, $\pm 1\%$ , 5 W	26-43	Dale Products, Inc. #RS-5
R223	Resistor: fixed, wirewound, 1,500 ohms, $\pm 1\%$ , 5 W	26-43	Dale Products, Inc. #RS-5
R224	Resistor: fixed, composition, 3,030 ohms, $\pm 1\%$ , 1 W	31-3030	HP
R225	Resistor: fixed, composition, 3,030 ohms, $\pm 1\%$ , 1 W	31-3030	HP
R226	Resistor: fixed, composition, 62,000 ohms, $\pm 5\%$ , 2 W	25-62K-5	B HB 6235
R227	Resistor: fixed, composition, 680 ohms, $\pm 10\%$ , 1 W	24-680	B GB 6811
R228	Resistor: fixed, composition, 150,000 ohms, $\pm 10\%$ , 1 W	24-150K	B GB 1541
R229	Resistor: fixed, composition, 220,000 ohms, $\pm 10\%$ , 1 W	24-220K	B GB 2241
R230	Resistor: fixed, composition, 22,000 ohms, $\pm 10\%$ , 2 W	25-22K	B HB 2231
R231	Resistor: fixed, composition, 5,100 ohms, $\pm 5\%$ , 1 W	24-74	B GB 5125
R232	Resistor: fixed, composition, 33,000 ohms, $\pm 10\%$ , 1 W	24-33K	B GB 3331
R233	Resistor: fixed, composition, 18,000 ohms, $\pm 10\%$ , 1 W	24-18K	B GB 1831
R234	Resistor: fixed, composition, 120,000 ohms, $\pm 10\%$ , 1 W	24-120K	B GB 1241
R235	Resistor: fixed, composition, 56,000 ohms, $\pm 1\%$ , 1 W	31-56K	HP
R236	Resistor: variable, wirewound, 10,000 ohms	210-72	G

\*See "List of Manufacturers Code Letters For Replaceable Parts Table."

355E 1/22/54 Serial 1 and above

TABLE OF REPLACEABLE PARTS

Circuit Ref.	Description	-hp- Stock No.	Mfr. * & Mfrs. Designation
R237	Resistor: fixed, composition, 56,000 ohms, $\pm 1\%$ , 1 W	31-56K	HP
R238	Resistor: fixed, composition, 100,000 ohms, $\pm 10\%$ , 1 W	24-100K	B GB 1041
R239	Resistor: fixed, wirewound, 1,700 ohms, $\pm 1\%$ , 5 W	26-44	Dale Products, Inc. #RS-5
R240	Resistor: fixed, wirewound, 255 ohms, $\pm 1\%$ , 5 W	26-40	Dale Products, Inc. #RS-5
R241	Resistor: fixed, composition 47,000 ohms, $\pm 10\%$ , 1 W	24-47K	B GB 4731
R242	Resistor: fixed, wirewound, 5,000 ohms, $\pm 1\%$ , 5 W	26-45	Dale Products, Inc. #RS-5
R243	Resistor: fixed, wirewound, 18,400 ohms, $\pm 1\%$ , 10 W	26-47	Dale Products, Inc. #RS-10
R244	Resistor: variable, wirewound, 100 ohms, $\pm 10\%$ , 2 W	210-4	I
R245	Resistor: variable, wirewound, 5,000 ohms, $\pm 10\%$ , 3 W	210-7	G, #21-010-357
R246	Resistor: fixed, wirewound, 3,000 ohms, $\pm 10\%$ , 1 W	26-3000	R, Type BW
R247	Dummy Meter Load Assembly 3,000 ohms	336C-53	HP
R248	Resistor: fixed, composition, 144,000 ohms, $\pm 1\%$ , 1 W	31-144K	HP
R249	Resistor: fixed, composition, 56,000 ohms, $\pm 10\%$ , 1 W	24-56K	B GB 5631
R250	Resistor: fixed, composition, 47 ohms, $\pm 10\%$ , 1 W	24-47	B GB 4701
R251	Resistor: fixed, composition, 10,000 ohms, $\pm 10\%$ , 2 W	25-10K	B HB 1031
R252	Resistor: fixed, composition, 22,000 ohms, $\pm 10\%$ , 1 W	24-22K	B GB 2231
R253	Resistor: fixed, composition 270,000 ohms, $\pm 10\%$ , 1 W	24-270K	B GB 2741

\*See "List of Manufacturers Code Letters For Replaceable Parts Table."

TABLE OF REPLACEABLE PARTS

Circuit Ref.	Description	-hp- Stock No.	Mfr. * & Mfrs. Designation
R254	Resistor: fixed, composition, 47,000 ohms, $\pm 10\%$ , 1 W	24-47K	B GB 4731
R255	Resistor: fixed, composition, 820 ohms, $\pm 10\%$ , 1 W	24-820	B GB 8211
R256	Resistor: fixed, composition, 270,000 ohms, $\pm 10\%$ , 1 W	24-270K	B GB 2741
R257	Resistor: fixed, composition, 100 ohms, $\pm 10\%$ , 1 W	24-100	B GB 1011
R258	Resistor: fixed, composition, 47,000 ohms, $\pm 10\%$ , 2 W	25-47K	B HB 4731
R259	Resistor: fixed, composition, 220,000 ohms, $\pm 10\%$ , 1 W	24-220K	B GB 2241
R260	Resistor: fixed, composition, 270,000 ohms, $\pm 10\%$ , 1 W	24-270K	B GB 2741
R261	Resistor: fixed, composition, 270,000 ohms, $\pm 10\%$ , 1 W	24-270K	B GB 2741
R262	Resistor: fixed, composition, 10,000 ohms, $\pm 10\%$ , 1 W	24-10K	B GB 1031
R263	Resistor: fixed, composition, 560,000 ohms, $\pm 10\%$ , 1 W	24-560K	B GB 5641
R264	Resistor: fixed, composition, 100,000 ohms, $\pm 10\%$ , 1 W	24-100K	B GB 1041
R265	Resistor: fixed, composition, 6,800 ohms, $\pm 10\%$ , 2 W	25-6800	B HB 6821
R266	Resistor: fixed, composition, 6,800 ohms, $\pm 10\%$ , 1 W	24-6800	B HB 6821
R267	Resistor: fixed, composition, 100,000 ohms, $\pm 10\%$ , 1 W	24-100K	B GB 1041
R268	Resistor: fixed, composition, 100,000 ohms, $\pm 10\%$ , 1 W	24-100K	B GB 1041
R269	Resistor: fixed, wirewound, 5,000 ohms, $\pm 1\%$ , 5 W	26-45	Dale Products, Inc. #RS-5
R270	Resistor: fixed, wirewound, 5,000 ohms, $\pm 1\%$ , 5 W	26-45	Dale Products, Inc. #RS-5

\*See "List of Manufacturers Code Letters For Replaceable Parts Table."

335E 1/22/54 Serial 1 and above

TABLE OF REPLACEABLE PARTS

Circuit Ref.	Description	-hp- Stock No.	Mfr. * & Mfrs. Designation
R271	Resistor: fixed, wirewound, 1,000 ohms, $\pm 10\%$ , 1 W	26-15	HP
R272	Resistor: fixed, composition, 1,800 ohms, $\pm 10\%$ , 1 W	24-1800	B GB 1821
R273	Resistor: fixed, wirewound, 6,200 ohms, $\pm 5\%$ , 2 W	26-32	R Type BW-2
R274	Resistor: variable, wirewound, 5,000 ohms, $\pm 10\%$ , 3 W	210-7	G #21-010-357
R275	Resistor: fixed, wirewound, 30,000 ohms, $\pm 5\%$ , 10 W	26-12	S Type 1-3/4E
R276	Resistor: fixed, composition, 100,000 ohms, $\pm 10\%$ , 1 W	24-100K	B GB 1041
R277	This circuit reference not assigned		
R278	Resistor: fixed, wirewound, 3,600 ohms, $\pm 5\%$ , 1 W	26-4	R Type BW
R279	Resistor: fixed, wirewound, 390 ohms, $\pm 1\%$ , 5 W	26-41	Dale Products, Inc. #RS-5
R280	Resistor: fixed, composition, 47,000 ohms, $\pm 10\%$ , 1 W	24-47K	B GB 473I
R281	Resistor: fixed, wirewound, 10,000 ohms, $\pm 10\%$ , 10 W	26-46	Dale Products, Inc. #RS-5
R282	Resistor: fixed, composition, 2,000 ohms, $\pm 20\%$ , 1/4 W	210-14	I #37-2000S
R283	Resistor: fixed, wirewound, 3,600 ohms, $\pm 5\%$ , 1 W	26-4	R Type BW
R284	Resistor: fixed, wirewound, 540 ohms, $\pm 1\%$ , 5 W	26-42	Dale Products, Inc. #RS-5
R285	Resistor: fixed, composition, 1,500 ohms, $\pm 10\%$ , 1 W Electrical value adjusted at factory	24-1500	B GB 1521
R286	Resistor: Electrical value adjusted at factory		
R287	Resistor: fixed, wirewound, 3,600 ohms, $\pm 5\%$ , 1 W	26-4	R Type BW

\*See "List of Manufacturers Code Letters For Replaceable Parts Table."

TABLE OF REPLACEABLE PARTS

Circuit Ref.	Description	-hp- Stock No.	Mfr. * & Mfrs. Designation
R288 - R300	These circuit references not assigned		
R301	Resistor: variable, wirewound 300 ohms,	210-53	G #21-010-358
R302	This circuit reference not assigned		
R303	Resistor: fixed, composition, 1 megohm, $\pm 10\%$ , 1 W	24-1M	B GB 1051
R304	Resistor: fixed, composition, 47 ohms, $\pm 10\%$ , 1 W	24-47	B GB 4701
R305	Resistor: fixed, composition, 2,200 ohms, $\pm 10\%$ , 1 W	24-2200	B GB 2221
R306	Resistor: fixed, composition, 27,000 ohms, $\pm 10\%$ , 2 W	25-27K	B GB 2731
R307	Resistor: fixed, composition, 1 megohm, $\pm 10\%$ , 1 W	24-1M	B GB 1051
R308	Resistor: fixed, composition, 220,000 ohms, $\pm 10\%$ , 1 W	24-220K	B GB 2241
R309	Resistor: fixed, composition, 1 megohm, $\pm 10\%$ , 1 W	24-1M	B GB 1051
R310	Resistor: fixed, composition, 47,000 ohms, $\pm 10\%$ , 1 W	24-47K	B GB 4731
R311	Resistor: fixed, composition 216,000 ohms, $\pm 1\%$ , 1 W	31-216.3K	HP
R312	Resistor: variable, wirewound 25,000 ohms, $\pm 10\%$ , 3 W	210-10	I #58-25000
R313	Resistor: fixed, composition, 14,400 ohms, $\pm 1\%$ , 1 W	31-14.4K	HP
R314	Resistor: fixed, composition, 1 megohm, $\pm 10\%$ , 1 W	24-1M	B GB 1051
R315	Resistor: fixed, composition, 180,000 ohms, $\pm 10\%$ , 1 W	24-180K	B GB 1841
R316	Resistor: variable, wirewound, 20,000 ohms, linear taper	210-79	B

\*See "List of Manufacturers Code Letters For Replaceable Parts Table."

335E 1/22/54 Serial 1 and above

TABLE OF REPLACEABLE PARTS

Circuit Ref.	Description	-hp- Stock No.	Mfr. * & Mfrs. Designation
R317	Resistor: fixed, composition, 100,000 ohms, ±10%, 1 W	24-100K	B GB 1041
R318	Resistor: fixed, composition, 6,800 ohms, ±10%, 2 W	25-6800	B HB 6821
R319	Resistor: fixed, composition, 6,800 ohms, ±10%, 2 W	25-6800	B HB 6821
R320	Resistor: fixed, composition, 100,000 ohms, ±10%, 1 W	24-100K	B GB 1041
R321	Resistor: fixed, composition, 100 ohms, ±10%, 1 W	24-100	B GB 1011
R322	Resistor: fixed, composition, 560 ohms, ±10%, 1 W	24-560	B GB 5611
R323	Resistor: fixed, composition, 560,000 ohms, ±10%, 1 W	24-560K	B GB 5641
R324	Resistor: fixed, wirewound, 5000 ohms, ±10%, 10 W	26-8	S Type 1-3/4E
L13, C229	Audio Filter Assembly:	336C-42	HP
C15, C232	Audio Filter Assembly:	336C-42	HP
	Power Cable:	M-72	HP
	Panel Connector: RF INPUTS	G-76A	HP
	Connector: EXTERNAL METERS	38-72	Industrial Prod.Co. UG 88/U
	Connector: UG 21B/U	38-74	Industrial Prod. Co. #4300
	Crystal Oven: for XTAL-1	G-69B-1	HP
	Crystal Oven: for XTAL-2	G-69A	HP
CR1, CR2, CR4, CR5, CR7, CR8	Crystal Rectifier: <i>Hughes</i> <del>1N35</del> <i>1N135 or 1N48</i>	212-G11A	HP
CR3, CR6	Crystal Bridge:	335E-11	HP
L1	RF Coil:	335E-60D	HP
L2	RF Coil:	335E-60B	HP

\*See "List of Manufacturers Code Letters For Replaceable Parts Table."

335E 1/22/54 Serial 1 and above



TABLE OF REPLACEABLE PARTS

Circuit Ref.	Description	-hp- Stock No.	Mfr. * & Mfrs. Designation
L3	RF Coil:	335E-60A	HP
L4, L5	These circuit references not assigned		
L6	Variable RF Coil: 60-100 $\mu$ h	48-19	North Hills Electric 110-G
L7	RF Reactor:	35F-60D	HP
L8	Variable RF Coil: 60-100 $\mu$ h	48-19	North Hills Electric P. O. Box 427 Great Neck, N. Y. 110-G
L9	RF Coil:	335E-60A	HP
L10	RF Coil: 2 $\mu$ h	48-1	HP
L11	RF Coil: 2 $\mu$ h	48-1	HP
L12	RF Coil:	335E-60C	HP
L13	Part of Audio Filter Assembly	336C-42	
L14	Reactor:	911-19	HP
L15	Part of Audio Filter Assembly	336C-42	
L16	RF Coil: 2 $\mu$ h	48-1	HP
L17	RF Coil: 2 $\mu$ h	48-1	HP
L18	Reactor: 6 h @ 125 MA, 240 ohms	911-4	HP
L19	Reactor: 6 h @ 125 MA, 240 ohms	911-4	HP
L20	Variable Coil: 3 to 5.5 $\mu$ h	335-60E	HP
L21	RF Coil:	48-1	HP
L22	RF Coil:	48-1	HP
	Fan Blade:	314-6	HP
	Fan Motor:	314-13	HP
	Air Filter:	314-21	HP
F1	Fuse: 3.2 amp.	211-45	T, #31303.2
F2	Fuse: 1/2 amp., 250 volts	211-20	E MDL 1/2
	Air Filter Oil: 16 fl. oz., includes sprayer	314-18	Research Prod. Corp. Madison 10, Wisc.

\*See "List of Manufacturers Code Letters For Replaceable Parts Table."

335E 1/22/54 Serial 1 and above

TABLE OF REPLACEABLE PARTS

Circuit Ref.	Description	-hp- Stock No.	Mfr. * & Mfrs. Designation
	Fuseholder:	140-16	T #342003
	Knob: 1" diam.	37-9	HP
	Knob: 1-1/2" diam.	37-11	HP
	Lampholder:	145-5	II, #100D
	Lamp: 6W, 120 v for Peak Modulation Indicator	211-5	O
	Lamp: 6-8 v, min. bayonet base	---	O
M1	Meter: "Visual Carrier Deviation"	112-44	HP
M2	Meter: "Aural Carrier Deviation"	112-46	HP
M3	Meter: "Percent Modulation Aural Carrier"	112-45	HP
P101	Motor Base Socket	38-52	N #2711
XTAL-1	Quartz:	Specify Frequency	HP
XTAL-2	Quartz Crystal: 4.3535 Mc	41-32	HP
XTAL-3	Quartz Crystal: 150 Kc	41-31	HP
SR1-SR8	Metallic Rectifier: 200 MA	212-85	M #1006
SR9	Metallic Rectifier:	212-73	M #1014
REL-1	Relay:	49-17	HP
	Relay Cover:	49-17A	HP
S1	Push Button Switch:	310-75	D #3391-E
S2	Rotary Switch:	310-114	HP
S3	Toggle Switch: SPDT	310-54	D 82305-B
S4	Toggle Switch: SPST	310-11	D
J1, J5	Telephone Jack:	38-10	X, #A2A
	Terminal Strip: 8 term.	36-38	H, Jones Div. #8-141-Y

\*See "List of Manufacturers Code Letters For Replaceable Parts Table."

TABLE OF REPLACEABLE PARTS

Circuit Ref.	Description	-hp- Stock No.	Mfr. * & Mfrs. Designation
	Terminal Strip: 2 term.	36-103	H, Jones Div. #2-140-3/4-W
	Thermometer: for Crystal Oven 1	41-30	HP
T1	Audio Input Transformer:	912-34	HP
T2	Audio Output Transformer:	912-8	HP
T3	Filament Transformer:	910-102	Sola Electric Co. #30492
T4	Power Transformer:	910-99	HP
T5	Power Transformer:	910-103	HP
	Tube Shield: 1-3/4" high	38-28	H, #8861
	Tube Shield: 2-1/4" high	38-68	Hugh H. Eby, Inc. Philadelphia, Pa. #9702-19
	Tube Shield: 1-15/16" high	38-159	H, #12627
	Tube Shield: for tube V1	120-4	HP
V1AB	Tube: 6U8	212-6U8	ZZ
V2	Tube: 6AH6	212-6AH6	ZZ
V3AB	Tube: 12AT7	212-12AT7	ZZ
V4	Tube: 12AT7	212-12AT7	ZZ
V5AB	Tube: 12AT7	212-12AT7	ZZ
V6AB	Tube: 12AT7	212-12AT7	ZZ
V7	Tube: 12AT7	212-12AT7	ZZ
V8AB	Tube: 5687	212-5687	ZZ
V9AB	Tube: 5687	212-5687	ZZ
V10	Tube: 6AH6	212-6AH6	ZZ
V11AB	Tube: 12AT7	212-12AT7	ZZ
V12AB	Tube: 5687	212-5687	ZZ
V13AB	Tube: 12AT7	212-12AT7	ZZ
V14AB	Tube: 12AT7	212-12AT7	ZZ
V15AB	Tube: 5687	212-5687	ZZ
V16AB	Tube: 12AT7	212-12AT7	ZZ
V17	Tube: 2D21	212-2D21	ZZ
V18	Tube: 6SJ7	212-6SJ7	ZZ
V19AB	Tube: 6AS7	212-6AS7	ZZ
V20	Tube: 6AH6	212-6AH6	ZZ
V21	Tube: OB2	212-OB2	ZZ
V22	Tube: 12AT7	212-12AT7	ZZ

\*See "List of Manufacturers Code Letters For Replaceable Parts Table."

335E 1/22/54 Serial 1 and above

LIST OF MANUFACTURERS CODE LETTERS  
FOR REPLACEABLE PARTS TABLE

<u>Code Letter</u>	<u>Manufacturer</u>
A	Aerovox Corp.
B	Allen-Bradley Co.
C	Amperite Co.
D	Arrow, Hart and Hegeman
E	Bussman Manufacturing Co.
F	Carborundum Co.
G	Centralab
H	Cinch Manufacturing Co.
HP	Hewlett-Packard
I	Clarostat Manufacturing Co.
J	Cornell Dubilier Electric Co.
K	Hi-Q Division of Aerovox Corp.
L	Erie Resistor Corp.
M	Federal Telephone and Radio Corp.
N	General Electric Co.
O	General Electric Supply Corp.
P	Girard-Hopkins
R	International Resistance Co.
S	Lectrohm, Inc.
T	Littelfuse, Inc.
V	Micamold Radio Corp.
X	P. R. Mallory Co., Inc.
Z	Sangamo Electric Co.
AA	Sarkes Tarzian
CC	Sprague Electric Co.
DD	Stackpole Carbon Co.
EE	Sylvania Electric Products, Inc.
FF	Western Electric Co.
HH	Amphenol
II	Dial Light Co. of America
KK	Switchcraft, Inc.
LL	Gremar Mfg. Co.
MM	Carad Corp.
ZZ	Any tube having RETMA standard characteristics

## CLAIM FOR DAMAGE IN SHIPMENT

The instrument should be tested as soon as it is received. If it fails to operate properly, or is damaged in any way, a claim should be filed with the carrier. A full report of the damage should be obtained by the claim agent, and this report should be forwarded to us. We will then advise you of the disposition to be made of the equipment and arrange for repair or replacement. Include model number, type number and serial number when referring to this instrument for any reason.

## WARRANTY

Hewlett-Packard Company warrants each instrument manufactured by them to be free from defects in material and workmanship. Our liability under this warranty is limited to servicing or adjusting any instrument returned to the factory for that purpose and to replace any defective parts thereof (except tubes, fuses and batteries). This warranty is effective for one year after delivery to the original purchaser when the instrument is returned, transportation charges prepaid by the original purchaser, and which upon our examination is disclosed to our satisfaction to be defective. If the fault has been caused by misuse or abnormal conditions of operation, repairs will be billed at cost. In this case, an estimate will be submitted before the work is started.

If any fault develops, the following steps should be taken:

1. Notify us, giving full details of the difficulty, and include the model number, type number and serial number. On receipt of this information, we will give you service instruction or shipping data.

2. On receipt of shipping instruction, forward the instrument prepaid, and repairs will be made at the factory. If requested, an estimate of the charges will be made before the work begins provided the instrument is not covered by the warranty.

## SHIPPING

All shipments of Hewlett-Packard instruments should be made via Railway Express. The instruments should be packed in a wooden box and surrounded by two to three inches of excelsior or similar shock-absorbing material.

## DO NOT HESITATE TO CALL ON US

HEWLETT-PACKARD COMPANY

*Laboratory Instruments* for *Speed and Accuracy*

395 PAGE MILL ROAD



PALO ALTO, CALIFORNIA

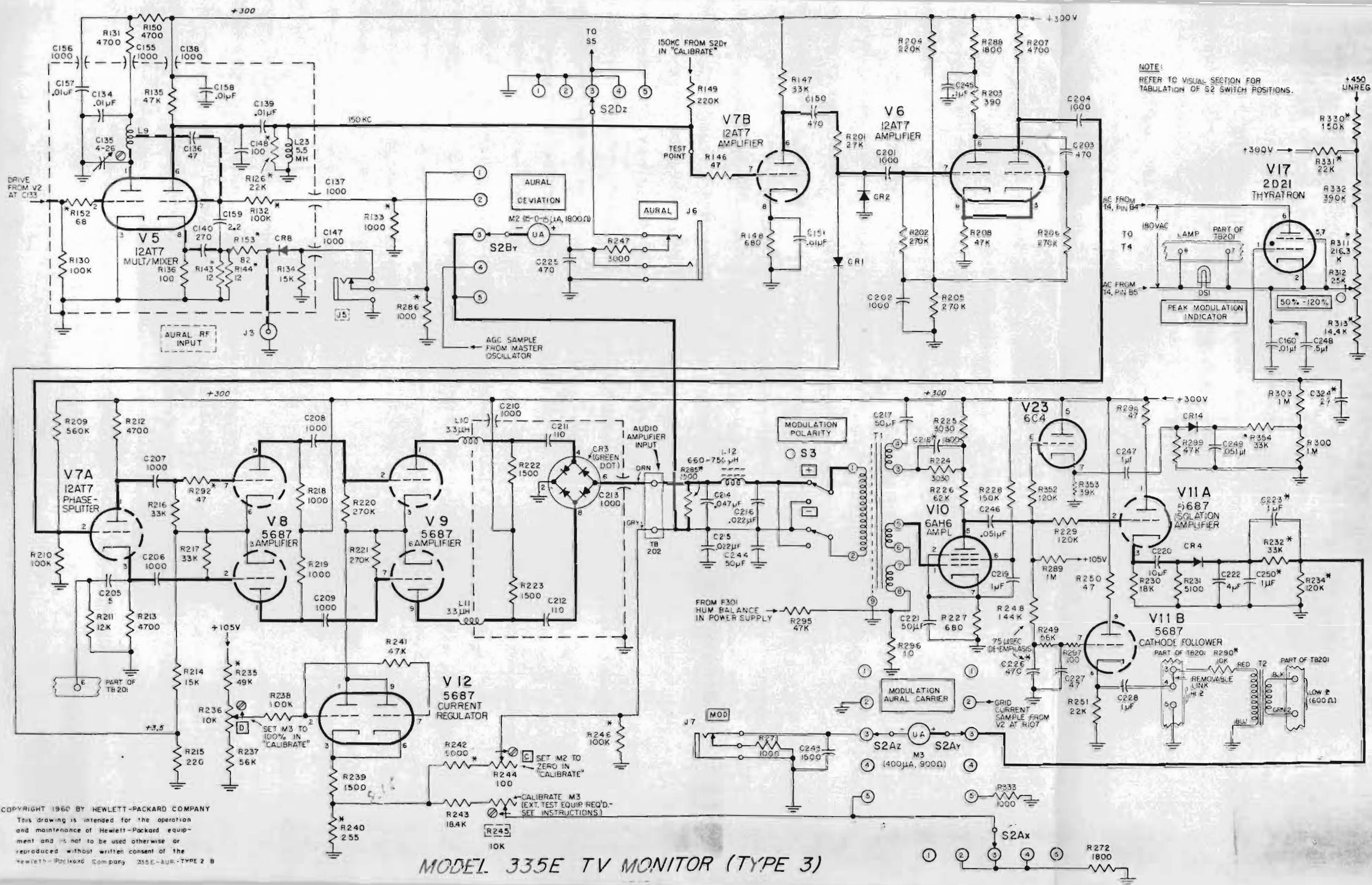

NOTE:  
REFER TO VISUAL SECTION FOR  
TABULATION OF S2 SWITCH POSITIONS.

COPYRIGHT 1960 BY HEWLETT-PACKARD COMPANY  
This drawing is intended for the operation  
and maintenance of Hewlett-Packard equip-  
ment and is not to be used otherwise or  
reproduced without written consent of the  
Hewlett-Packard Company 335E-AUR-TYPE 2 B

MODEL 335E TV MONITOR (TYPE 3)

*Use Diagram 1A back of Book 1*

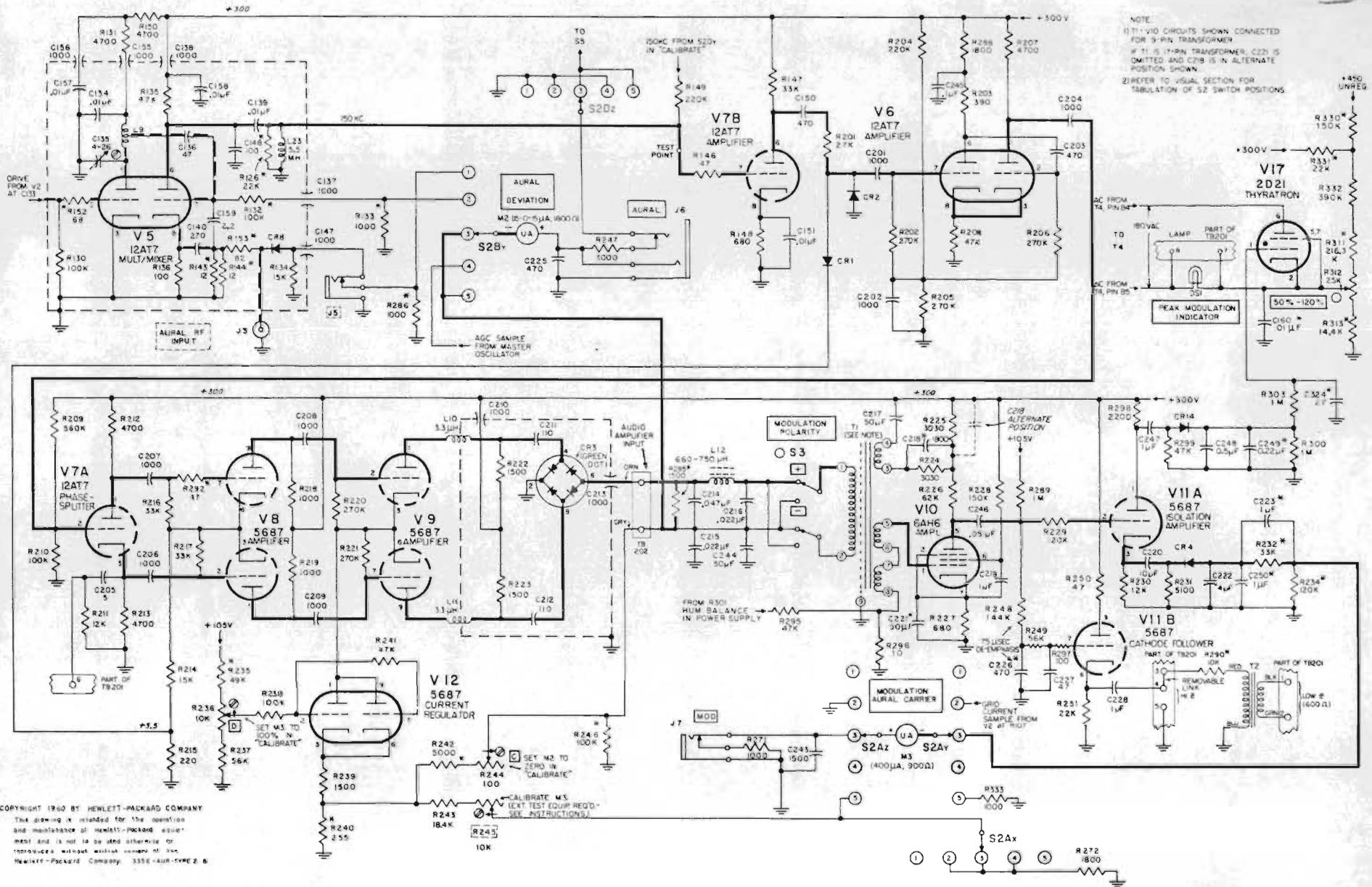
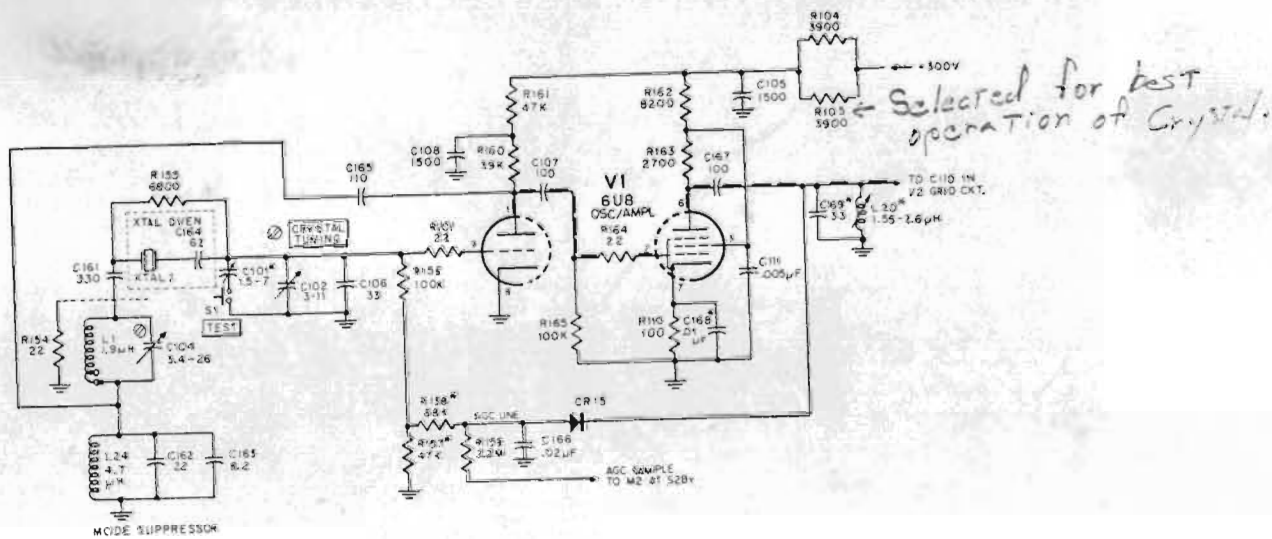

Figure 4-14. Aural Circuits



COPYRIGHT 1960 BY HEWLETT-PACKARD COMPANY  
 This drawing is intended for the operation and maintenance of Hewlett-Packard equipment and it is to be used otherwise or reproduced without written consent of the Hewlett-Packard Company. 0110-40-0000 2

Figure 4-12. Master Oscillator



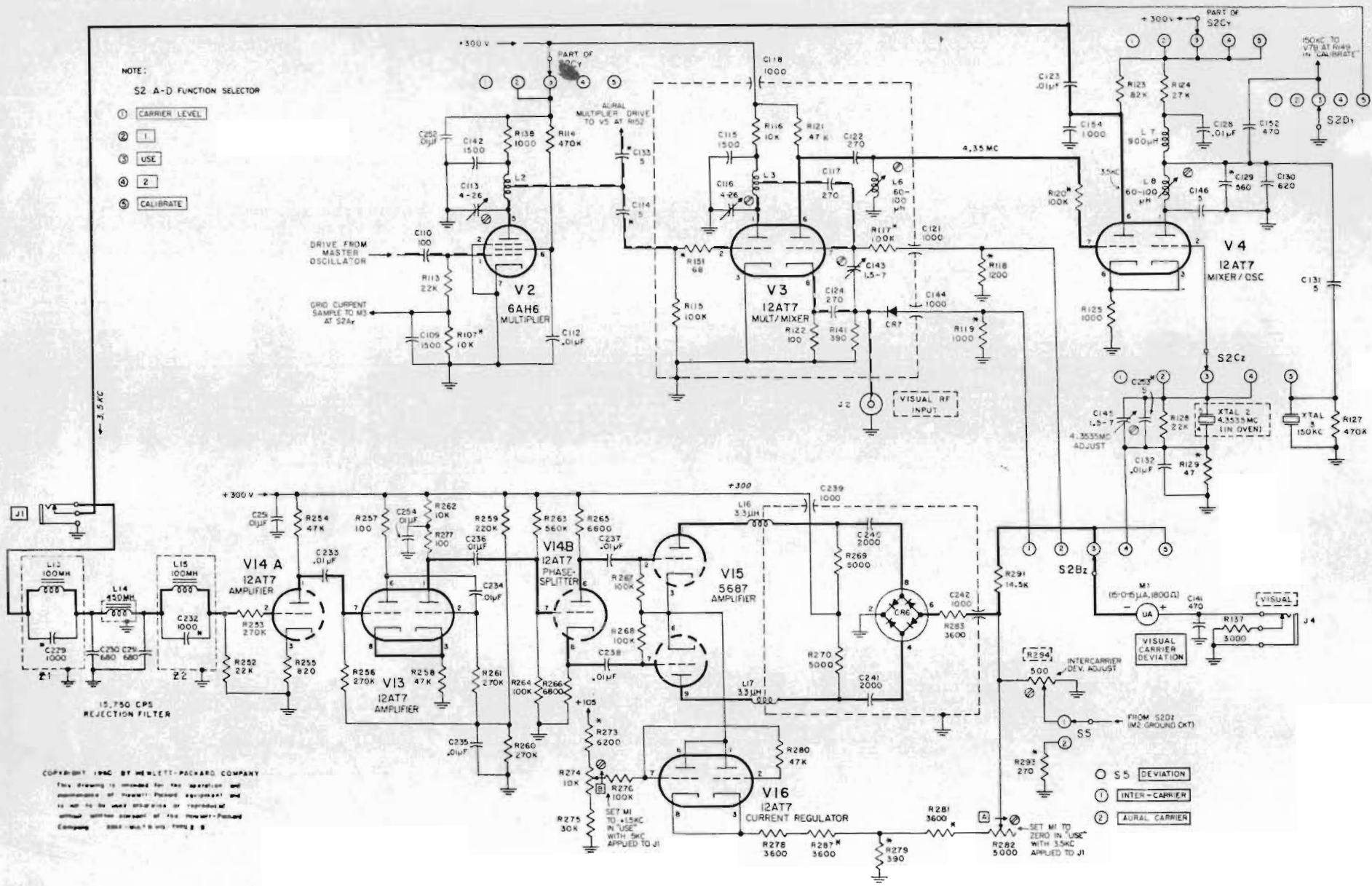

Figure 4-13. Visual Circuits

- S2 A-H
- ① CARRIER LEVEL
- ② 1
- ③ USE
- ④ 2
- ⑤ CALIBRATE

NOTES:

CONDITIONS OF DC VOLTAGE MEASUREMENT

1. LINE VOLTAGE AT 115 VOLTS, 50/60~
  2. NO RF INPUT
  3. DUMMY METER LOADS CONNECTED
  4. [MODULATION POLARITY] SWITCH AT + POSITION
  5. PEAK MODULATION INDICATOR (50%-100%) CONTROL AT 100%
  6. VOLTAGES MEASURED BETWEEN INDICATED POINTS AND CHASSIS WITH VOLTMETER OF 122 MEGOHMS INPUT RESISTANCE
  7. (+250) INDICATES VOLTAGES MEASURED IN [USE] POSITION
  - +250 INDICATES VOLTAGES MEASURED IN [CALIBRATE] POSITION
- ALL CAPACITANCE IN  $\mu\text{F}$  RESISTANCE IN OHMS UNLESS OTHERWISE NOTED  
 K = 1000 OHMS M = 1 MEGOHM  $\text{---}$  CHASSIS  $\text{---}$  CATHODE

- PANEL CONTROL
- ⊗ SCREWDRIVER ADJ.

\* = ADJUSTED AT FACTORY FOR OPTIMUM PERFORMANCE. AVERAGE VALUE SHOWN

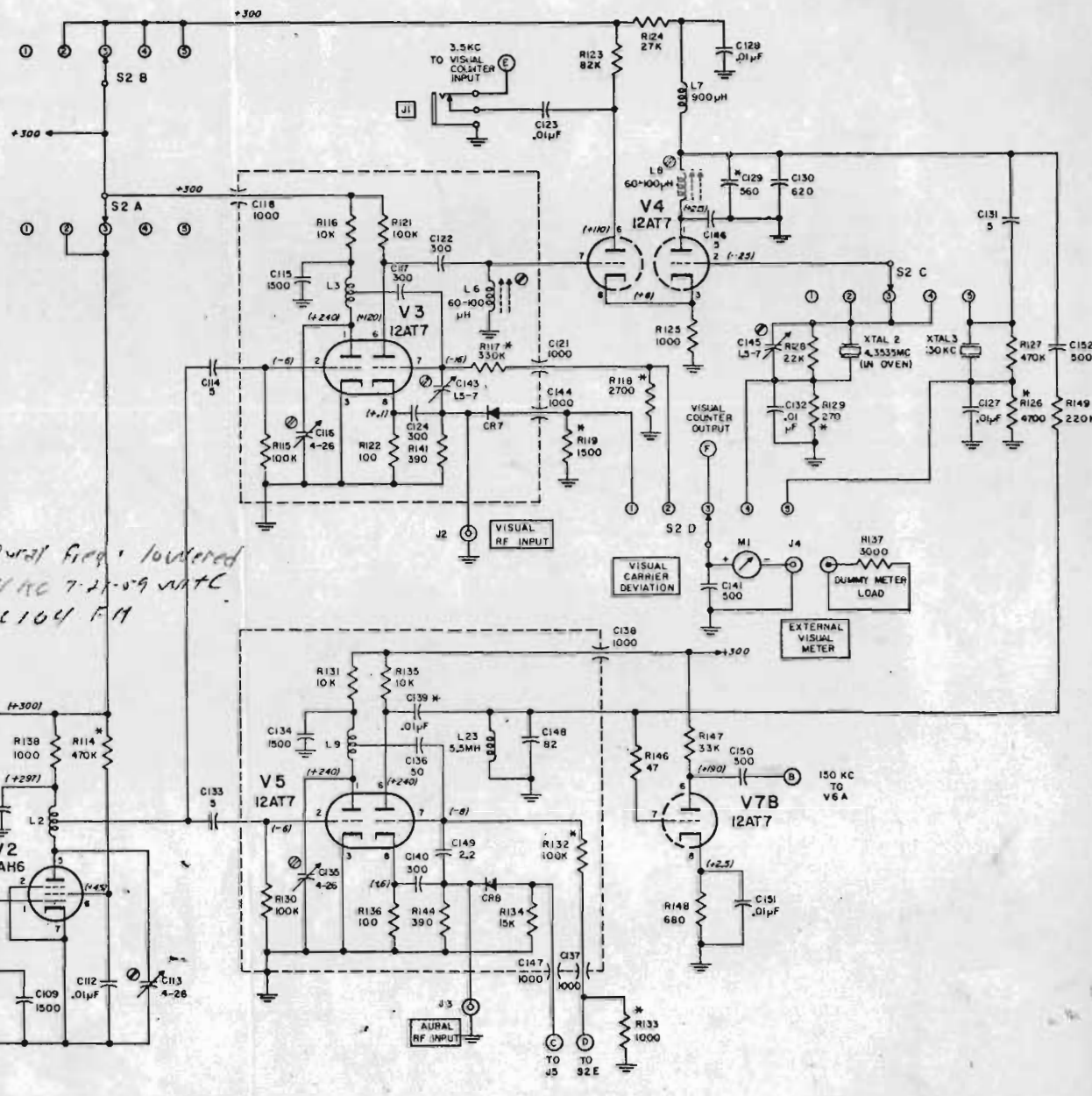

*Aural freq. indication raised .4 KC 6-19-56. F.H. with C104*  
*Aural freq. lowered .4 KC 7-21-59 WATC*  
*Aural freq. 1770 lowered .4 KC C104 F.H.*  
*11-18-56 WITH C104 F.H.*

**SCHEMATIC DIAGRAM OF MODEL 335E**  
 TELEVISION MONITOR

(RF SECTION)  
SERIAL I & ABOVE

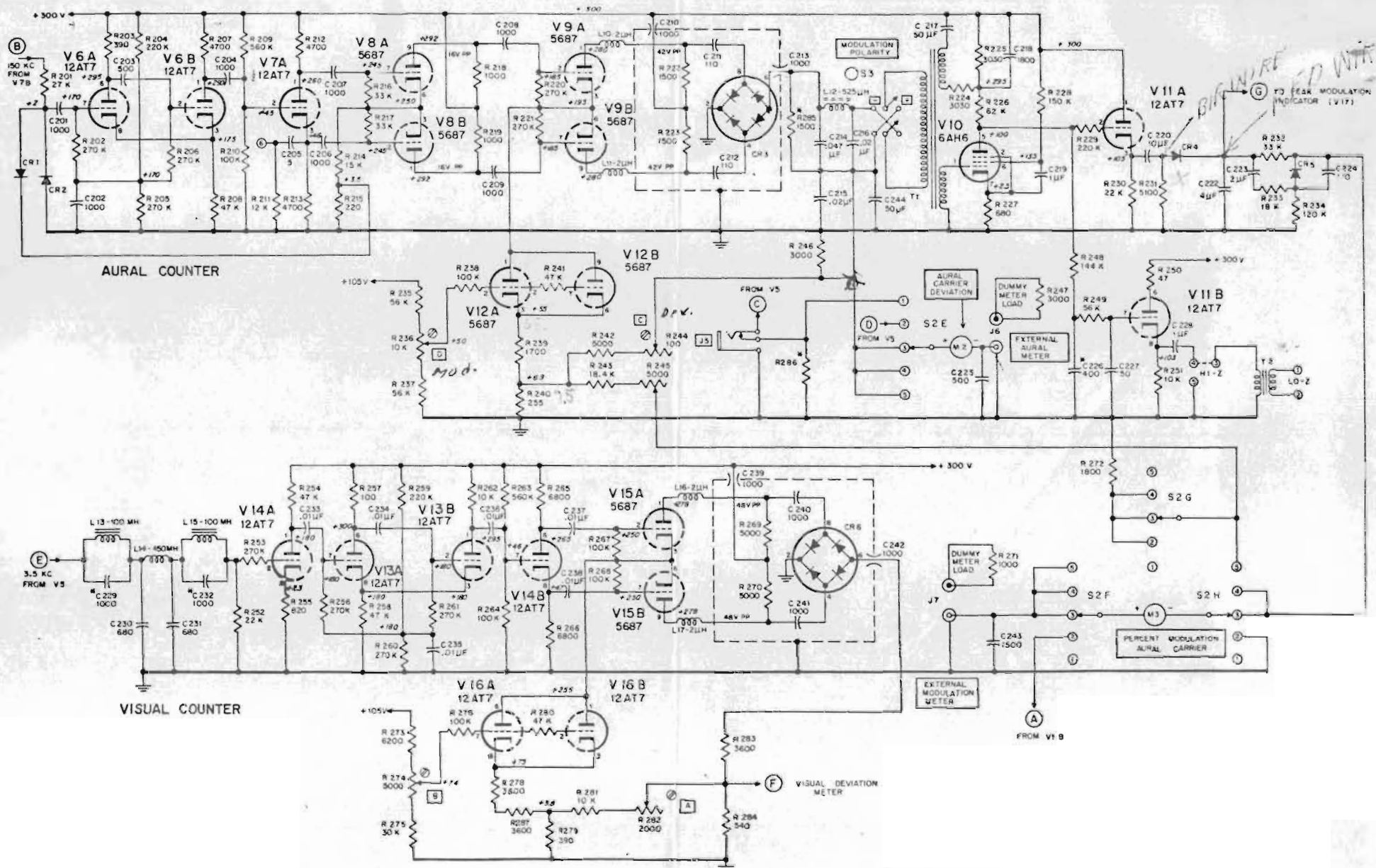

SCHMATIC DIAGRAM OF MODEL 335E  
TELEVISION MONITOR  
(COUNTER SECTION)  
SERIAL I & ABOVE

# HEWLETT-PACKARD COMPANY

*Laboratory Instruments for Speed and Accuracy*

395 PAGE MILL ROAD, PALO ALTO, CALIFORNIA

PHONE DAVENPORT 5-4451

April 16, 1954

Station W S L I  
Standard Life B/C Co.  
Jackson, Mississippi

Purchase Order No. 73509

Gentlemen:

We are enclosing the following instruction manual (s)  
due on your Purchase Order No. EC-32177-4 :

<u>Model No.</u>	<u>Serial No.</u>
335E	15

This data was not shipped with your order for the rea-  
son checked below:

- ( ) 1. Manual temporarily out of print.
- ( X ) 2. Shipped preliminary book pending completion  
of manual.
- ( ) 3. Manual in process of preparation.

We regret the delay in completing your order and hope  
it has not inconvenienced you.

Sincerely yours,

HEWLETT-PACKARD COMPANY

*Edward F. Doten*

Edward F. Doten  
Instruction Book Department

EFD/bc  
Enclosure.



# TENTATIVE DATA

-hp- MODEL 335E

## FREQUENCY MONITOR AND MODULATION METER FOR TV BROADCAST STATIONS

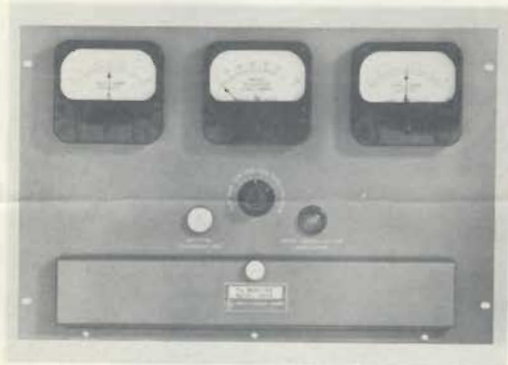

### APPLICATION

This new -hp- instrument monitors the carrier frequencies of both the aural and video TV transmitters, and measures the degree of aural modulation. No adjustments are necessary during operation, and because the accuracy does not depend on a tuned circuit, it is not necessary to re-set the carrier level or re-align circuits. The instrument is specifically designed to operate without adjustment week after week. It gives continuous indication of broadcast frequencies and aural modulating level at all times, and assures that your transmitter is operating within FCC specifications.

### DESCRIPTION

The -hp- 335E includes provision for operation of remote indicating meters as well as a remote peak modulation indicator lamp. The percentage modulation at which the lamp flashes a warning is adjusted on the front panel.

An audio output signal, provided for measurement purposes, has residual distortion of less than 0.25% and the noise level is at least 70 db below 100% modulation at low frequencies. Frequency response is flat within 0.5 db of standard de-emphasis curve, 50 to 15,000 cps. A demodulated signal for remote or local aural monitoring is also provided at least at a 0 VU level.

### ADVANTAGES

- \* Assures that your transmitter is within FCC specifications for frequency accuracy and degree of aural modulation.
- \* Operates reliably, accurately over long periods of time.
- \* No adjustments required during operation.
- \* Covers all TV channels, 2 to 83.
- \* Compact size, requires minimum rack space.
- \* Available in special finishes to match your transmitter color scheme.
- \* Indicating meters can be remotely located.

SPECIFICATIONS

Aural Frequency Monitor

Deviation Range: +6 kc to -6 kc mean frequency deviation.  
Accuracy: Better than  $\pm 1,000$  cps for at least 10 days.

Aural Modulation Meter

Modulation Range: Meter reads full scale on modulation swing of 33.3 kc. Scale calibrated to 100% at 25 kc swing; 133% at 33.3 kc swing.  
Accuracy: Within 5% modulation percentage over entire scale.  
Meter Characteristics: Meter damped in accordance F.C.C. requirements. Reads peak value of modulation peak of duration between 40 and 90 milliseconds. Meter returns from full reading to 10% of full value within 500 to 800 milliseconds.

Frequency Response: Flat within  $\pm 1/2$  db from 50 to 15,000 cps.

Modulation Peak Indicator

Peak Flash Range: From 50% to 120% modulation (25 kc = 100%).

Video Frequency Monitor

Deviation Range: +1.5 kc to -1.5 kc mean frequency deviation.  
Accuracy: Better than  $\pm 500$  cps for at least 10 days.

Audio Output

Frequency Range: 50 to 15,000 cps. Response flat within  $\pm 1/2$  db. Equipped with standard 75 microsecond de-emphasis circuit.  
Distortion: Less than 0.25% at 100% modulation.  
Output Voltage: 10 volts into 20,000 ohms at 100% modulation at low frequencies.  
Monitoring Output: 1 milliwatt into 600 ohms, balanced, at 100% modulation, at low frequencies.  
Residual Noise: At least 70 db below output level corresponding to 100% modulation at low frequencies.

General

Frequency Range: Channels 2 to 83 inclusive, including offset channels.

R.F. Power Required: Approximately 2 watts.

External Meter Indication: External meter indication available for aural carrier deviation, video carrier deviation, aural modulation percentage and peak indication.

Size: <sup>24 1/2</sup>~~12 1/4~~" high x 19" wide x 13" deep - for rack mounting only.

Power: 115 volts, 50/60 cps, 180 watts.

Price: \$1,950.00 f. o. b. Palo Alto, California.

ABOVE DATA SUBJECT TO CHANGE WITHOUT NOTICE

HEWLETT-PACKARD COMPANY  
395 PAGE MILL ROAD  
PALO ALTO, CALIF.

2/27/53



# SERVICE NOTES

## PROCEDURE FOR REPLACING THE THERMOSTAT IN THE CRYSTAL OVEN OF THE HEWLETT-PACKARD MODEL 524B AND MODEL 335E

M-7

The crystal oven contains a thermostat to maintain a constant oven temperature which is within  $\pm 2^{\circ}$  of  $65^{\circ}\text{C}$ . If the temperature indicator is not in the green region, the thermostat has probably failed. The installation procedure is given below.

<u>Component</u>	<u>-hp- Stock Number</u>
Oven	G-69B
Thermostat for 524B	310-129
Thermostat for 335E	41-5

### REPLACEMENT PROCEDURE:

1. Remove the instrument case.
2. Unscrew the 3/8" nut on the temperature indicator shaft between the front panel and the crystal oven.
3. In the Model 524B remove Z 202. Twist the two L shaped clamp shafts (next to the tubes) 1/2 turn counterclockwise and pull out the complete assembly.
4. Remove thermometer.
5. Remove the four 6-32 screws, under the chassis, which screw into each corner of the crystal oven case.
6. Remove the crystal oven top by lifting it directly away from the chassis.
7. Remove the two 6-32 screws, in the lip of oven top, which hold the banana plug block. This loosens the block and makes the following steps easier.
8. Inside the crystal oven top is an aluminum casting which has a hole in one corner. The thermostat is located in this hole and is removed by gently pulling the wires which enter the hole.
9. Note the position of any springs, fiber tubes, or insulating coverings on the thermostat base. In the Model 524B there is a spring between the bottom of the hole in the casting and the thermostat top.
10. Unsolder the thermostat wires from the banana plug block.
11. Transfer the springs, etc., noted in step 9, to the new thermostat.
12. Install the new thermostat and reassemble the oven by reversing the above instructions.

7/29/54





## CAUTION

### READ BEFORE TURNING ON THE INSTRUMENT

INSTALLATION OR REPLACEMENT OF THE MERCURY SWITCH CONTACT THERMOMETER OR THE CRYSTAL OVEN IN THE HEWLETT-PACKARD MODELS 100B, 100C, 100D, 335B, AND 524A.

The heating of the crystal oven in these instruments is regulated by a mercury column switch in a contact thermometer. Occasionally the mercury column is separated by jarring and vibration of the unit in shipment.

Three types of ovens have been used. These are described below. This procedure is written to include directions for these three types, with suitable directions for each type separately where necessary.

Type 1: This type operates at approximately 55°C. It is bolted into the unit and wired directly to the other components.

Type 2: This type operates at approximately 65°C. It is self-contained and plugs into a socket.

Type 3: This is the same as type 2 except that it is assembled differently and requires a different procedure when replacing the contact thermometer.

After turning the instrument on for the first time, keep a close check on the temperature of the crystal oven as indicated by the thermometer in the front panel. When the instrument has been on about 30 minutes, the crystal oven should remain automatically at a rather constant temperature. This condition will be indicated by a shutting off of the crystal pilot lamp from time to time, and by the fact that the thermometer will reach a fairly steady reading of about 55° in type 1 or about 65° in types 2 & 3.

However, if the crystal pilot light stays on continuously, and if the thermometer goes up beyond 60 degrees in type 1 or 70 degrees in types 2 & 3, the mercury column in the thermostat switch or the temperature indicating thermometer has probably been separated in shipment. Turn the instrument off immediately and proceed as follows.

CAUTION: The contact thermometer is connected to the 115 volt AC line in most units; the instrument MUST BE UNPLUGGED before doing any work.

Step 1: Remove the instrument from its cabinet and inspect the temperature indicating thermometer. This is easily done and faults are usually evident. If mercury separating or air bubbles are present, remove this thermometer and either replace it or treat as outlined in step 5. If it appears satisfactory, proceed to step 2.

(Over)

Step 2: Remove the mercury switch contact thermometer as indicated below:

Type 1: In this type the contact thermometer is mounted in the side of the oven casting, and is removed by gently pulling it out. It is not necessary to remove the oven. Proceed to step 3.

Type 2: Unplug and remove the crystal oven unit. Remove the screws holding the temperature indicating thermometer bracket and pull the bracket and thermometer carefully from the oven. Remove the mercury switch bracket and three screws on the outside bottom of the oven casting and one screw on the top end of the unit. Remove cover and lift unit out of casting. Then remove the mercury switch from its recess in the inner casting. Proceed to step 3.

Type 3: Unplug and remove the crystal oven unit. Remove the guard around the contact thermometer and unscrew the two terminals where the contact thermometer is connected. Gently pull it from its recess in the oven unit. Proceed to step 3.

Step 3: All types. Inspect the mercury switch for mercury column separation and any minute air bubbles in mercury bulb. If either separation or air bubbles are present, proceed to step four. If neither is present and the trouble has been definitely traced to the contact thermometer, it is probable that the switch contact is open and the contact thermometer must be replaced. In this case proceed to step 6.

Step 4: Remove the contact thermometer from the instrument.

Type 1: The two leads are wired to the deck outside the oven. They are easily unsoldered for removal of the contact thermometer.

Type 2: The two leads are soldered inside pins 2 and 5 of the plug in the bottom of the casting. Heat the outside of these pins to remove the wires. The contact thermometer has already been removed in step 2.

Step 5: If either air bubbles or separation are present, place the mercury switch bulb in ice water until mercury occupies only the bulb compartment. Tip lightly to remove any bubbles or globules left in column. The temperature indicating thermometer may be treated in this same manner.

Place the bulb in a vessel of water and heat until mercury completely fills column and a small portion of the enlargement at top of column. Then remove the mercury switch and watch mercury descend to room temperature. If there is no separation or bubbles present, the mercury switch may now be put back in service. It may be necessary to repeat the above procedure more than once to unite all the mercury and remove all bubbles.

**CAUTION:** Immerse only bulb portion of mercury switch. If mercury switch leads get wet or any moisture collects beneath the elastic insulator covering the contact rings, remove the plastic insulator and dry tube, insulator, and leads thoroughly before placing back in service. Otherwise leakage between leads may cause heater relay to remain open.

Step 6: The mercury switch should be tested with an ohmmeter before replacing in the oven. Heat the mercury bulb. The ohmmeter should show an open circuit and then a short circuit as the column expands to reach both internal contacts. These are directly beneath the rings on the glass tube. Failure to do so indicates a defective switch which must be replaced. Proceed to step 7.

Step 7: Reassemble the entire oven unit.

CAUTION: In many units the contacts of the thermometer are connected to the A.C. power line. They MUST BE insulated from the casting by plastic sleeving or electrical tape.

Type 1: Insert the mercury switch as far as possible into the casting.

Type 2: When replacing the mercury column switch do not seat it any deeper than necessary; otherwise the temperature indicating thermometer will not seat to the necessary depth.

Type 3: Insert the mercury column switch as far as possible into the oven unit.

Step 8: Replace the oven unit in the instrument. Turn the instrument on and keep a check on the temperature indicating thermometer to be sure that it and the mercury column switch are now operating properly.

# PACKING LIST

**HEWLETT-PACKARD COMPANY**

*Laboratory Instruments for Speed and Accuracy*

395 PAGE MILL ROAD

PALO ALTO, CALIF.



CUSTOMER'S ORDER NO. EC-32177-4

REPRESENTATIVE JDR  
 GOVERNMENT   
 NON-GOVERNMENT

DATE 3-10-54

**SOLD TO**

General Electric Co.  
 Commercial Equipment  
 C&GED, Electronics Park, Bldg. 7  
 Syracuse, New York

**SHIP TO**

Station W S L I  
 Standard Life B/C Co.  
 Jackson, Mississippi

**SHIP**

**VIA**

**TERMS**

**INVOICE TO**

**MARK**

SHIPPING DATE

WAYBILL No.

TAXABLE  NON-TAXABLE

QUANTITY ORDERED	APPROX. SHIPPING DATE	QUANTITY SHIPPED	BALANCE DUE	DESCRIPTION	UNIT PRICE
1				<del>XXXX</del> -hp- Instruction Manual for 335E Serial No. 15	N/C

OUR ORDER 73509

WE APPRECIATE YOUR ORDER. THE ABOVE IS A COPY GIVEN TO OUR SHIPPING DEPARTMENT. PLEASE NOTIFY US PROMPTLY IF THERE IS ANY OMISSION OR ERROR.  
 HEWLETT-PACKARD COMPANY

THIS ORDER IS ACCEPTED SUBJECT TO THE CONDITIONS ON THE REVERSE SIDE. OUR RESPONSIBILITY CEASES WHEN GOODS ARE DELIVERED TO THE TRANSPORTATION CO. ALL CLAIMS FOR LOSS OR DAMAGE IN TRANSIT MUST BE MADE AGAINST THE CARRIER.

ALL PRICES ARE F. O. B. PALO ALTO UNLESS OTHERWISE SPECIFIED